

SPECIFICATION

Finish	RAL 9003
Materials	Mild Steel
Weight	0.4Kg. + Fitting
Ingress protection	IP65

Step 1 - Ensure that the hole to cover is within the the Minimum and Maximum Range

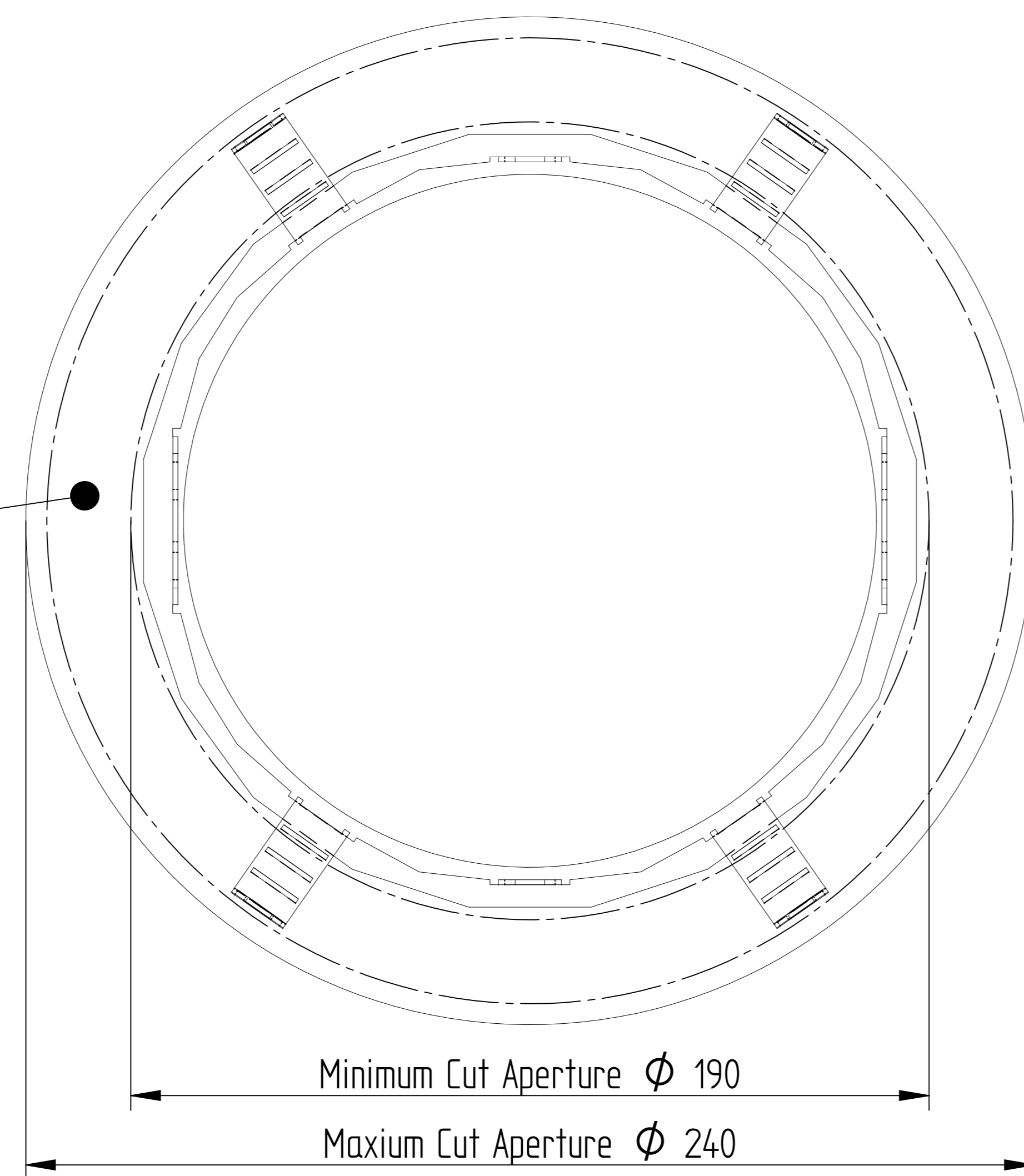
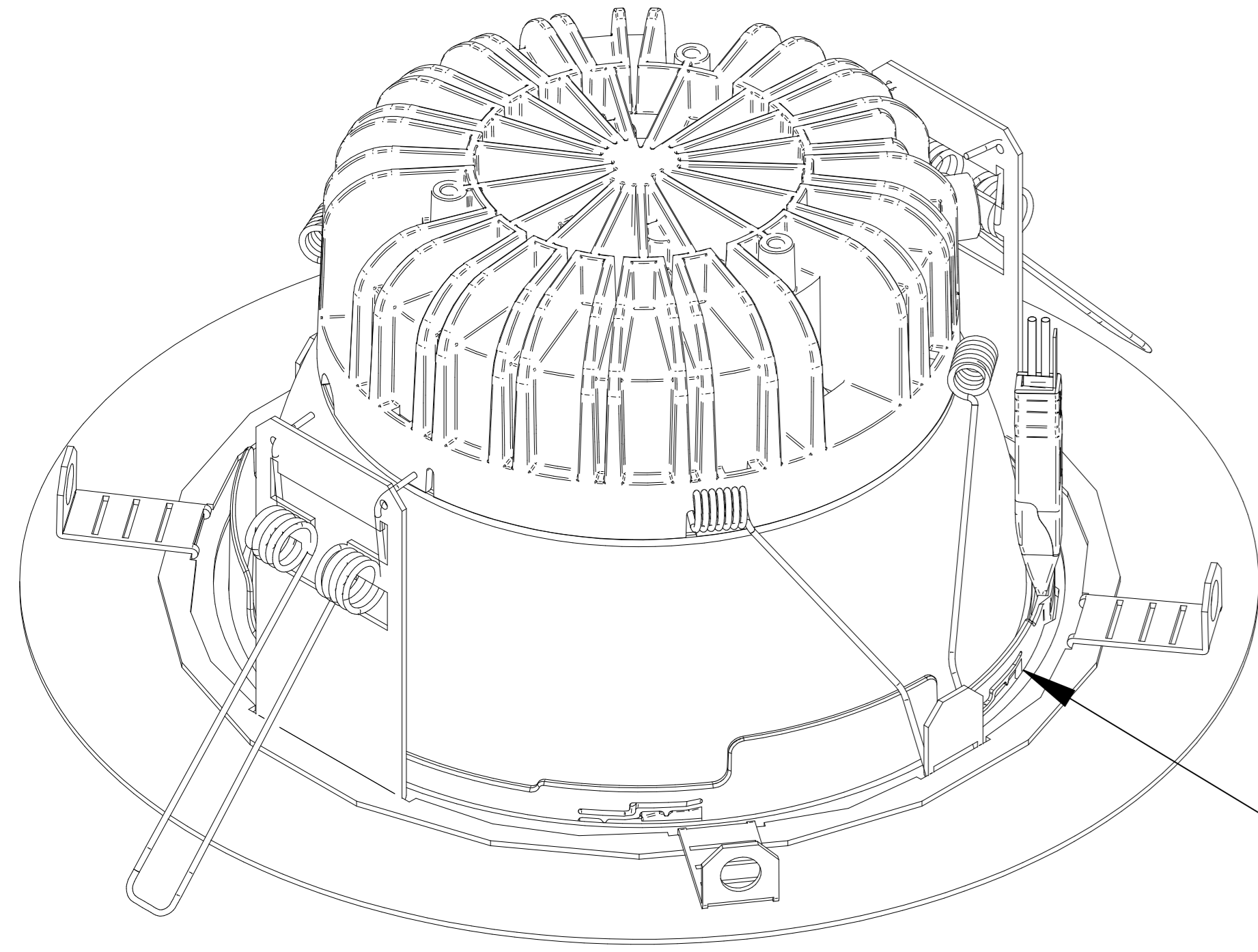

Step 2 - Install the fitting by bending up the springs 90 degrees then inserting them into the retro fit bezel aperture. Then releasing the product so that it pulls up flush to the retro fit bezel front surface. Ensure that the gasket on the product seal all the way around the aperture.

Step 3 - Fold 4 tabs as shown to centre the bezel in the hole there are a number of different easy folds for different diameters select bend closest to your hole size

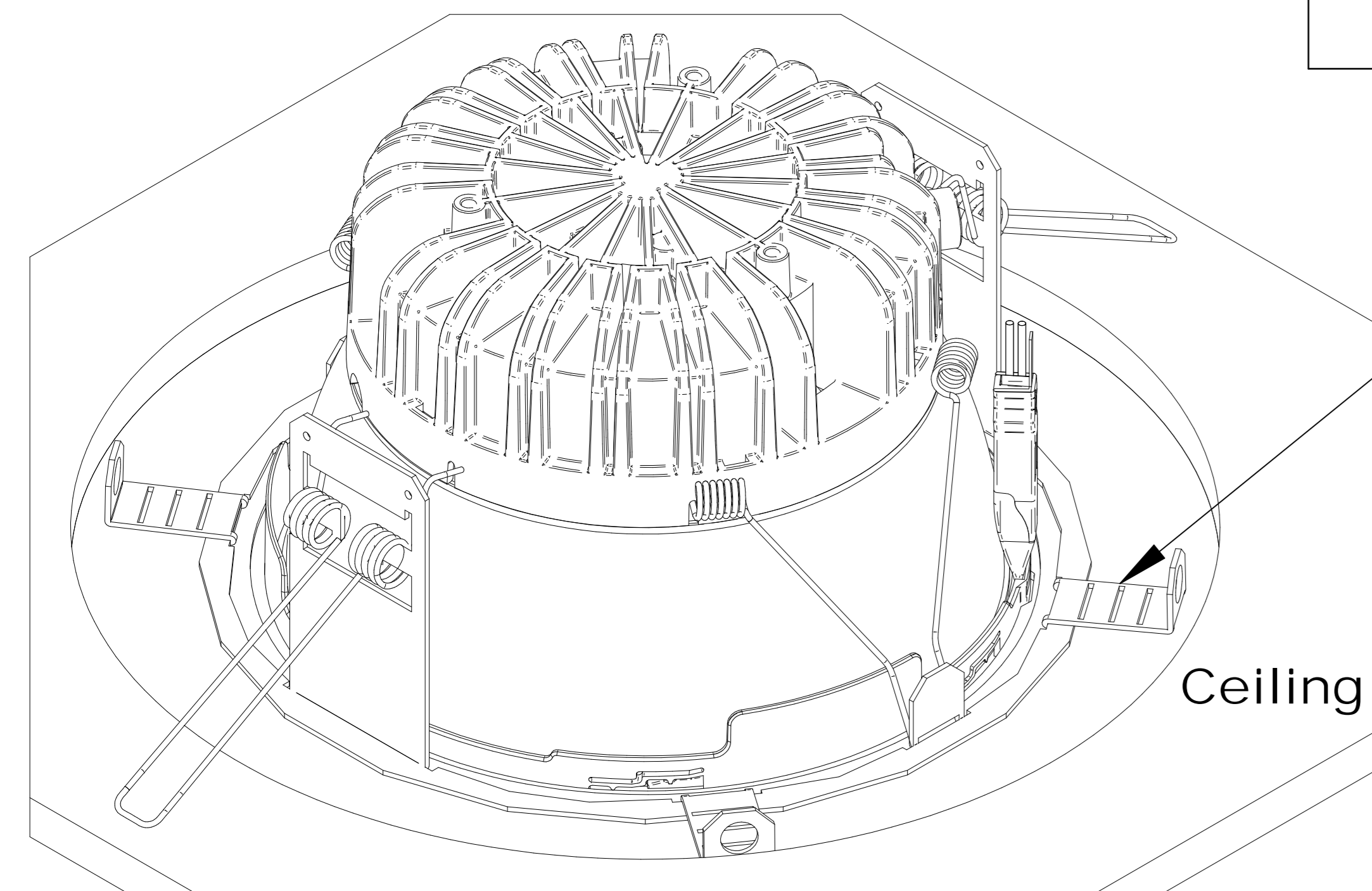

Ceiling

Step 4 - Apply mastic around the circumference of the bezel in one continuous loop to make a seal to the ceiling

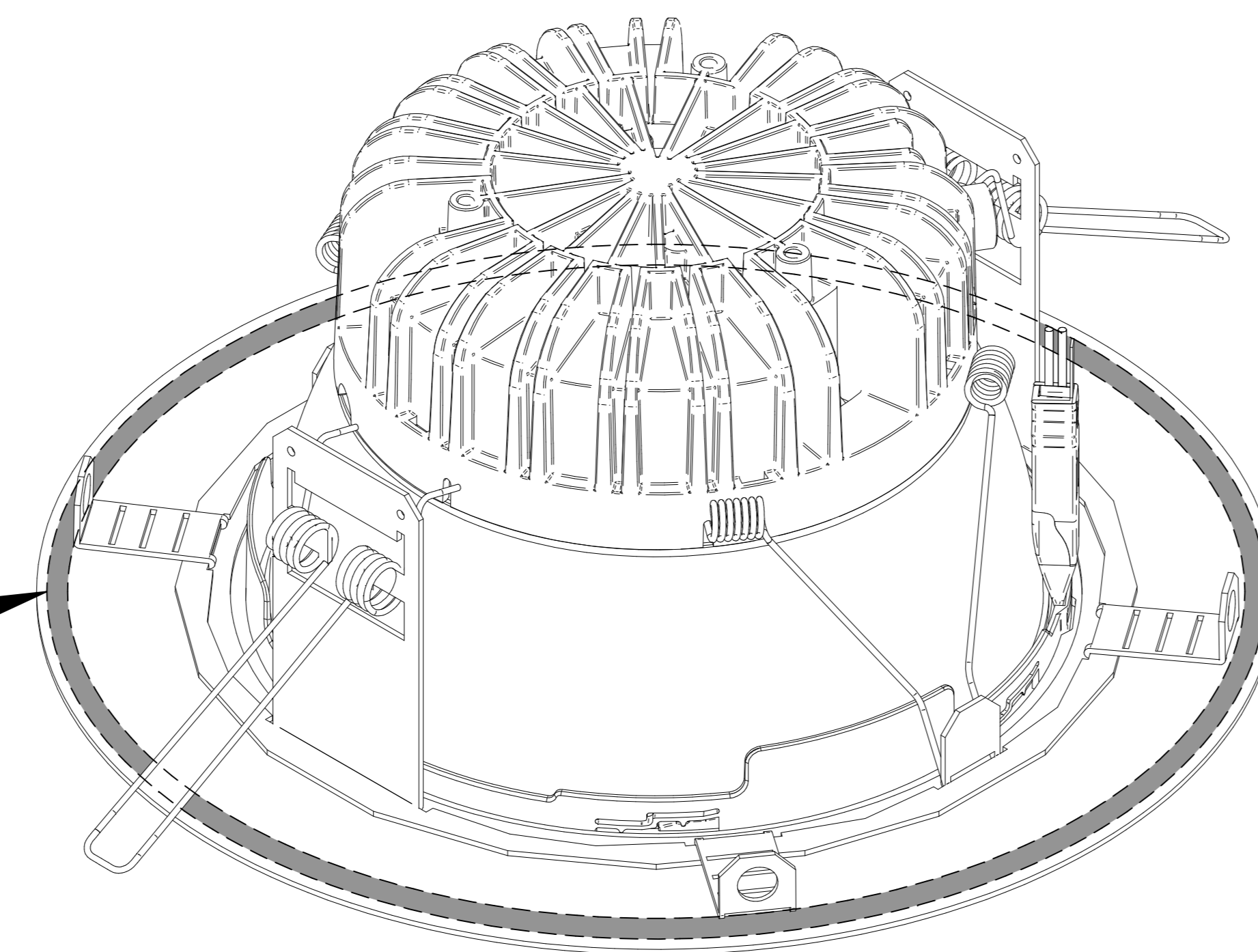

Step 5 - Connect the driver from the product up to the mains and any other controls cables required.

Step 6 - Fold back the springs on the retro fit bezel and place them through the ceiling void and release so that the bezel is held up against the ceiling

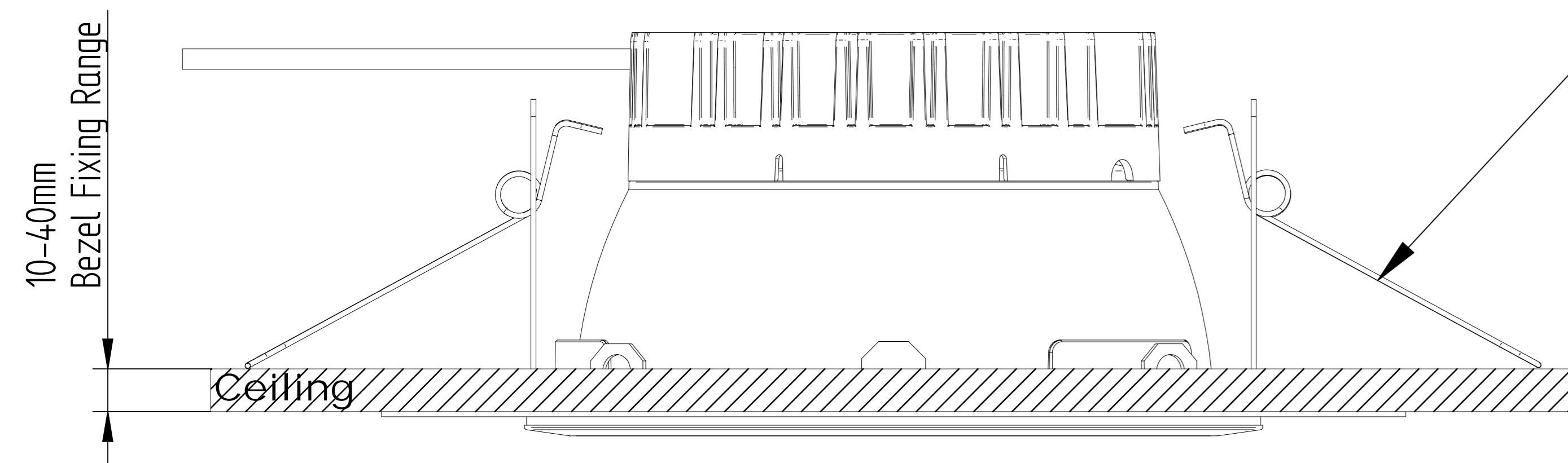

Ceiling

TECHNICAL SUPPORT

Telephone: 0161 331 5700
Email: technical@whitecroftlight.com
<http://whitecroftlighting.com/>

Whitecroft
lighting

Mirage 3 IP65 Retro Fit

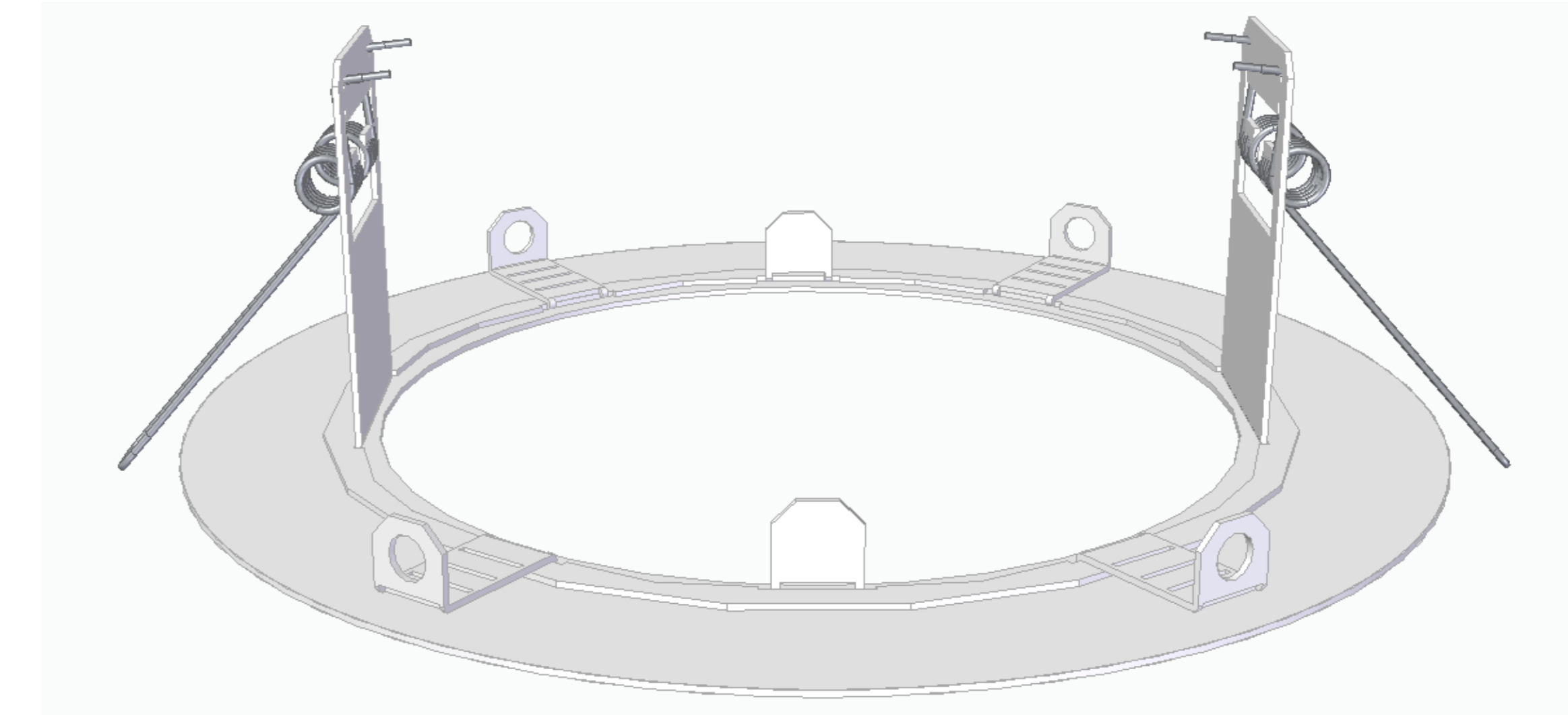

Installation Instruction

PK/M3IP65RETRO-IL

August 2021 - Rev A

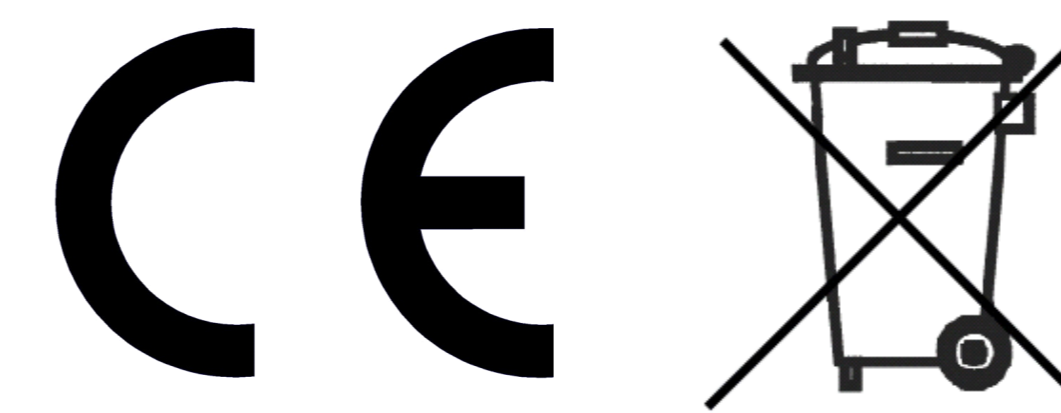

Whitecroft Lighting Limited

Burlington Street, Ashton-under-Lyne, Lancashire OL7 0AX
Telephone +44 (0)161 330 6811 Facsimile: +44 (0)161 331 5855
Registered No. 3848973 England Registered Office: As above