

### SPECIFICATION

Lamp type	LED
Finish	RAL 9003(White) / 9006(Silver)
Materials	Polycarbonate / Steel / Aluminium
Weight	Standard Fitting (Short) = 1.4kg Standard Fitting (Tall) = 1.8kg Emergency Fitting (Tall) = 2.2kg.
Supply	220-240V AC, 50/60Hz
Output	1100lm / 2000lm / 3000lm
Operating temp	0-30C°
Connection	1.5mm <sup>2</sup> input terminal block
Ingress protection	IP20

### DIMENSIONS

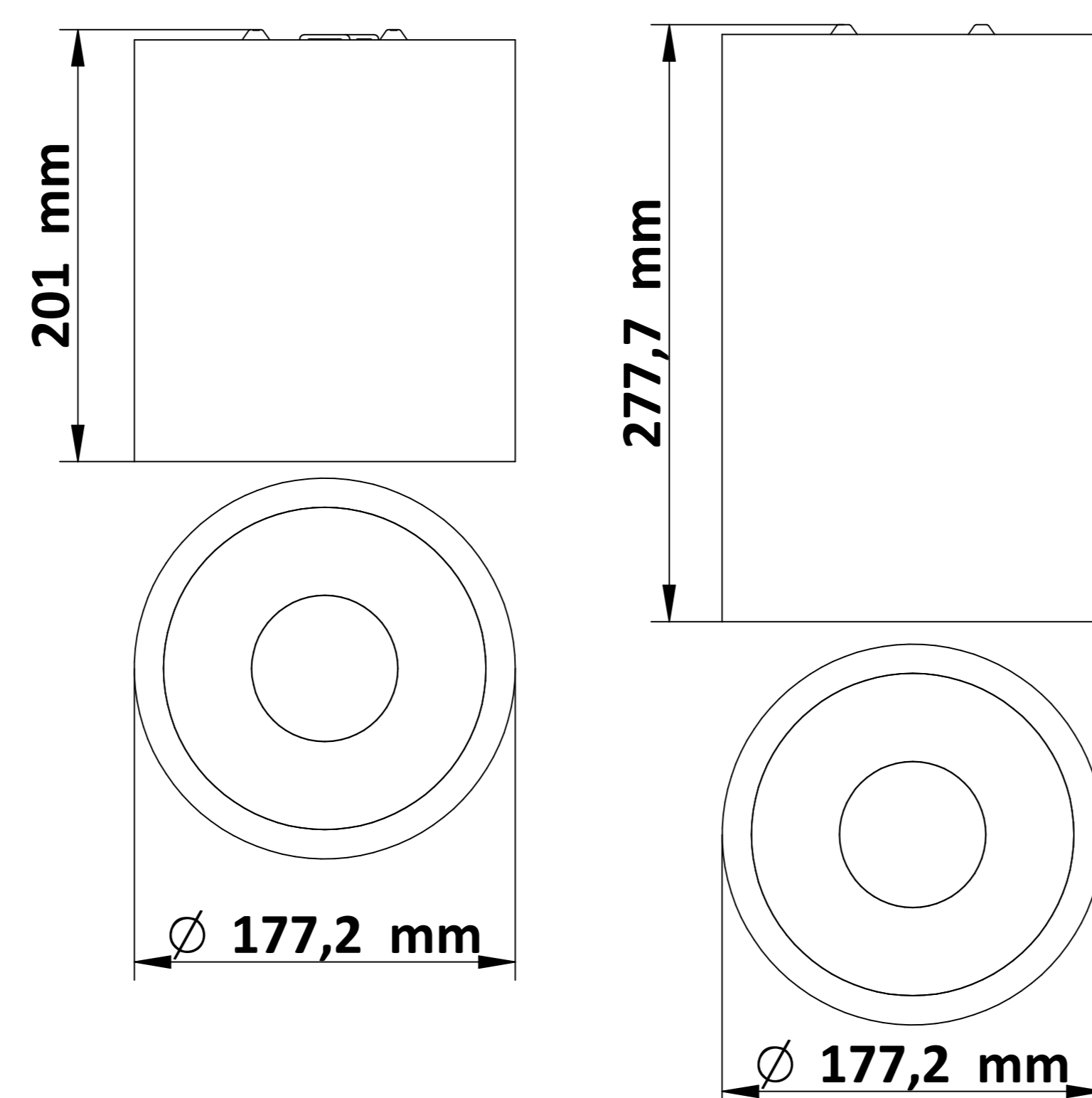

### GENERAL INFORMATION

- 1) A qualified electrician, in accordance with IEE wiring regulations should carry out connection to mains wiring.
- 2) This unit must be EARTHED.
- 3) Ensure that the rated voltage and frequency requirements are compatible with the available mains supply.
- 4) Cleaning of reflectors and lenses should be carried out using clean, soft and lint free cloths and anti-static cleaning fluid
- 5) Do not carry out high voltage insulation test, i.e. 500/1000v this may damage internal components.

#### TECHNICAL SUPPORT

Telephone: 0161 331 5700  
 Email: [technical@whitecroftlight.com](mailto:technical@whitecroftlight.com)  
<http://whitecroftlighting.com/>



# Mirage Surface LED

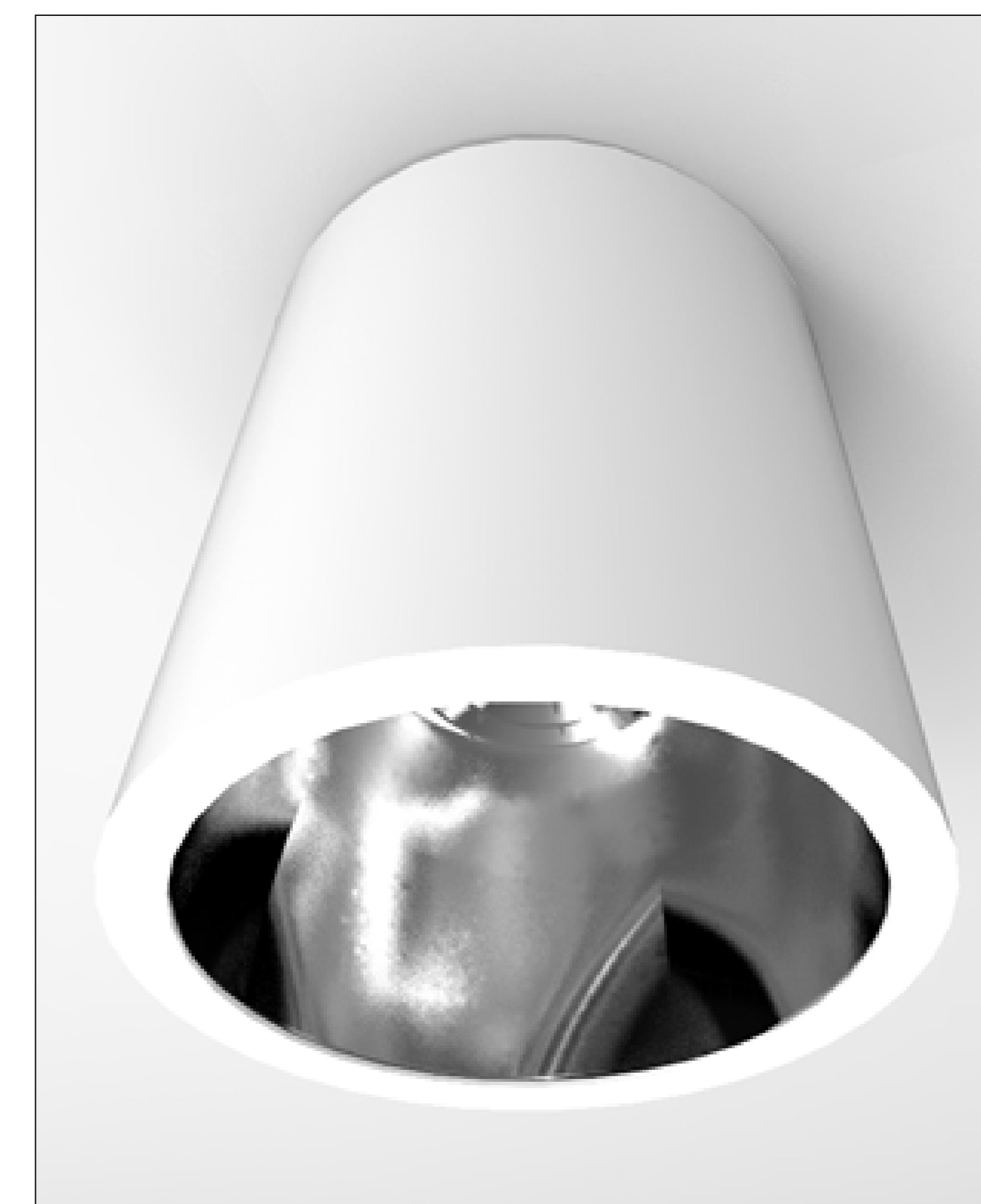

## Installation Instructions

PK/NPD143-IL

FEB 2023 - Rev F



## Whitecroft Lighting Limited

Burlington Street, Ashton-under-Lyne, Lancashire OL7 0AX  
 Telephone +44 (0)161 330 6811 Facsimile: +44 (0)161 331 5855  
 Registered No. 3848973 England Registered Office: As above

# Surface Downlighter

High Voltage LED's

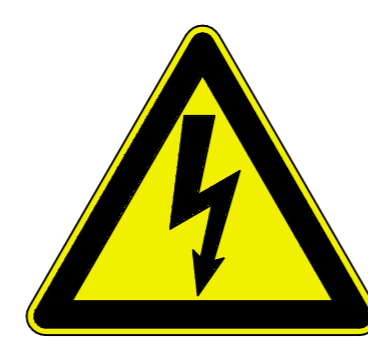

Electrostatic Sensitive Device



Whitcroft Lighting Limited

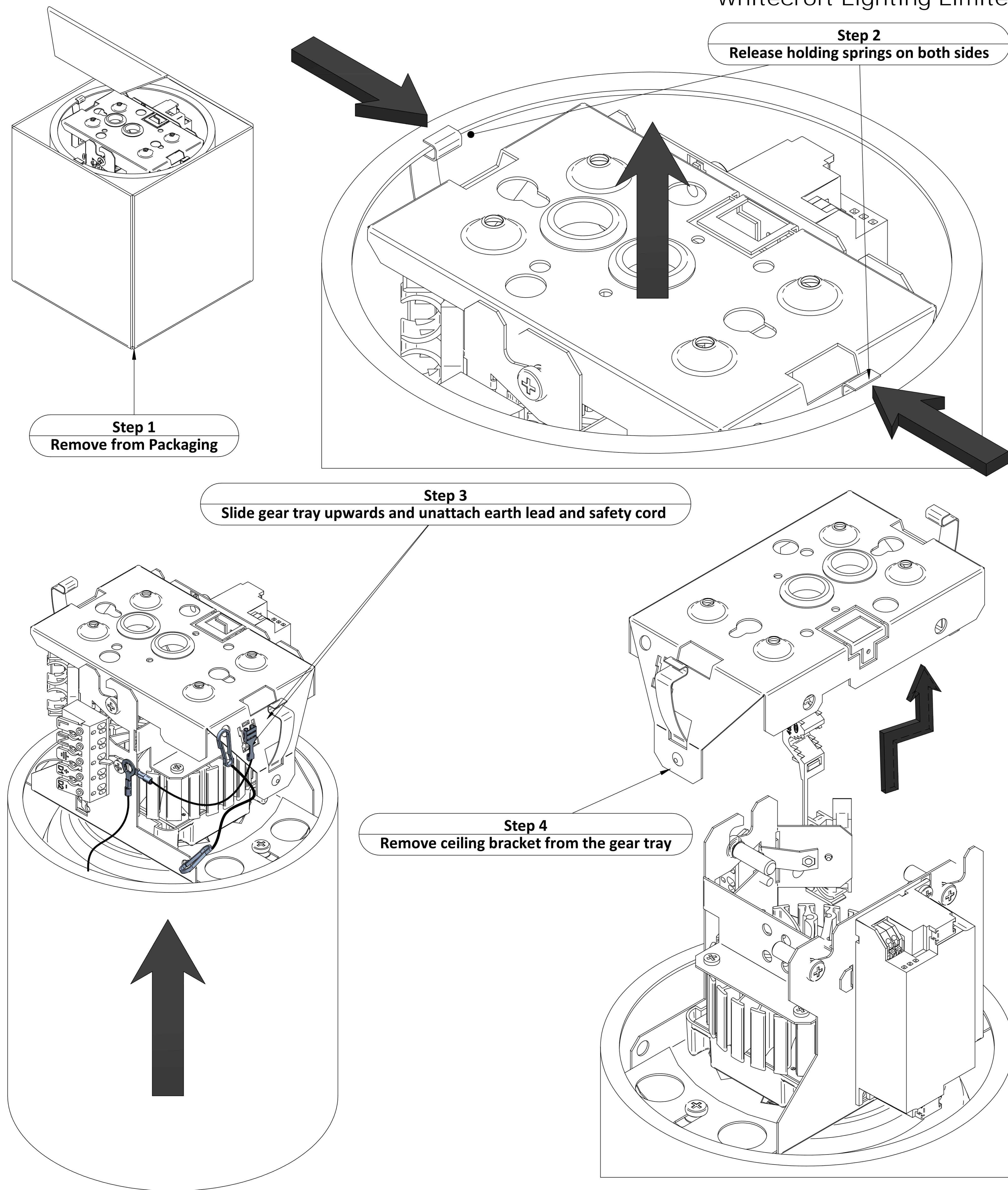

Screw Mounting Holes

Drop Rod Mounting Holes

BESA Mounting Holes

If required Cover Plate

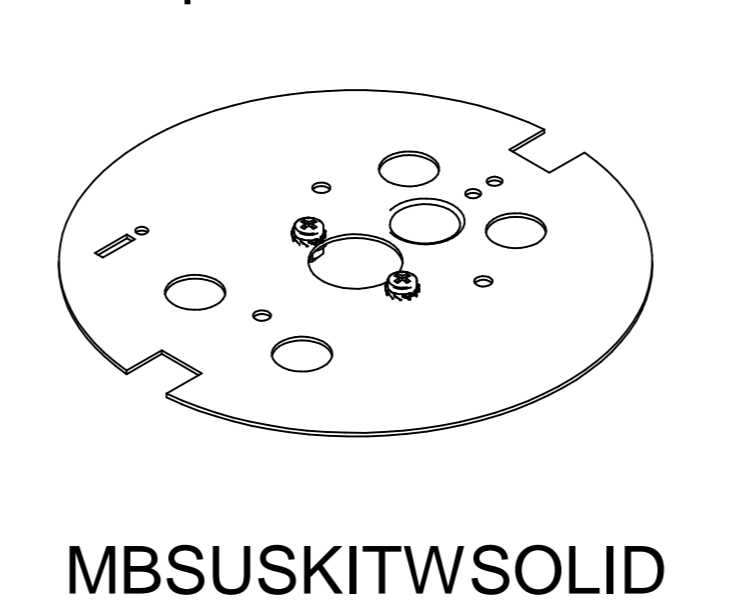
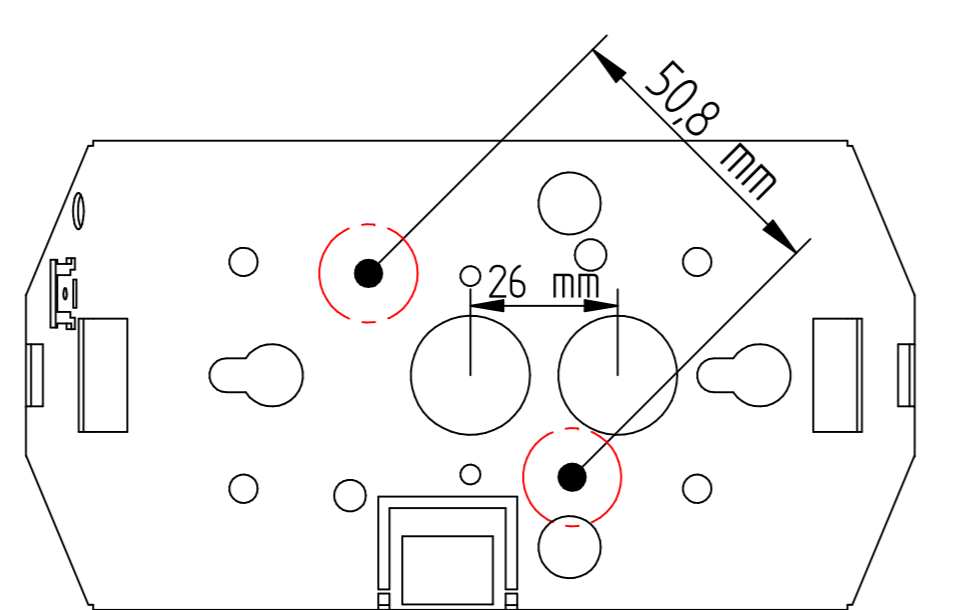
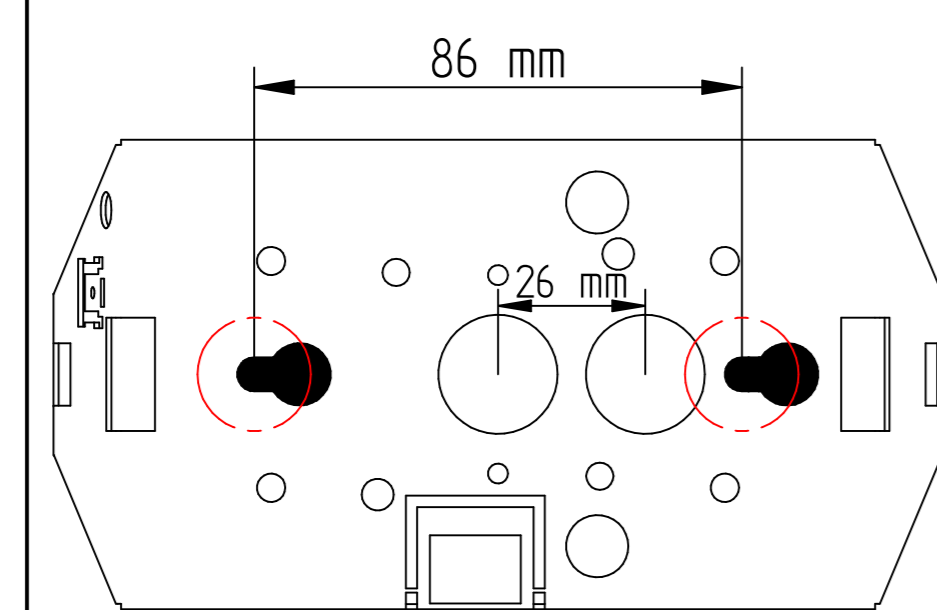
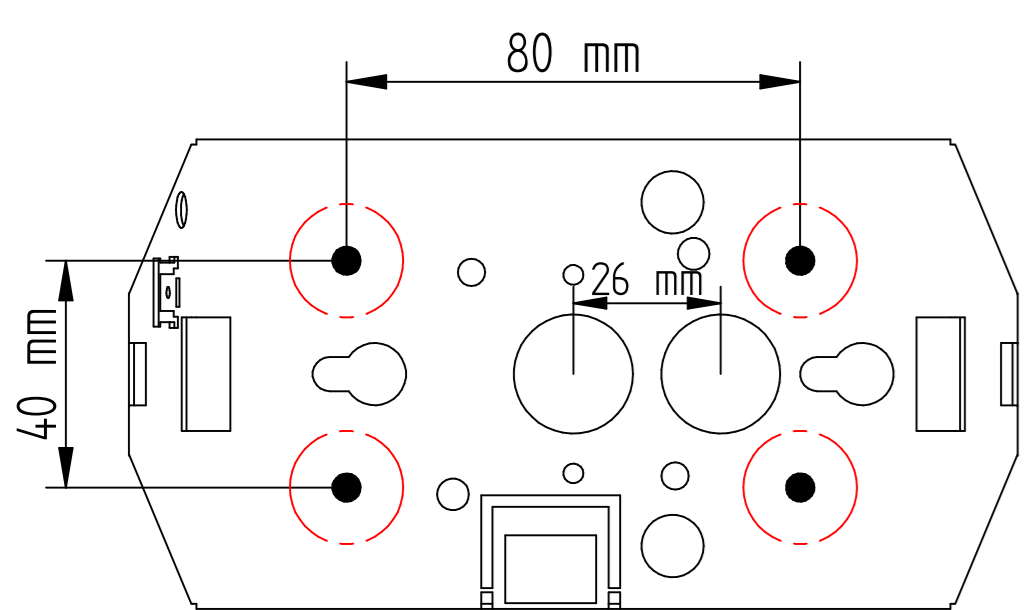

# Surface Downlighter

High Voltage LED's

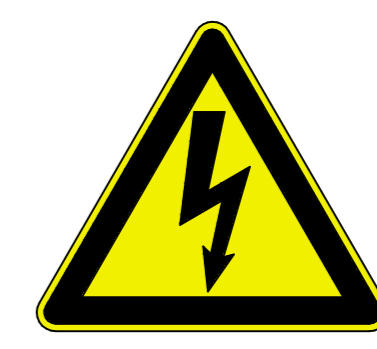

Electrostatic Sensitive Device

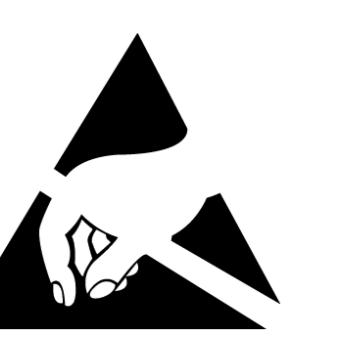

Whitcroft Lighting Limited

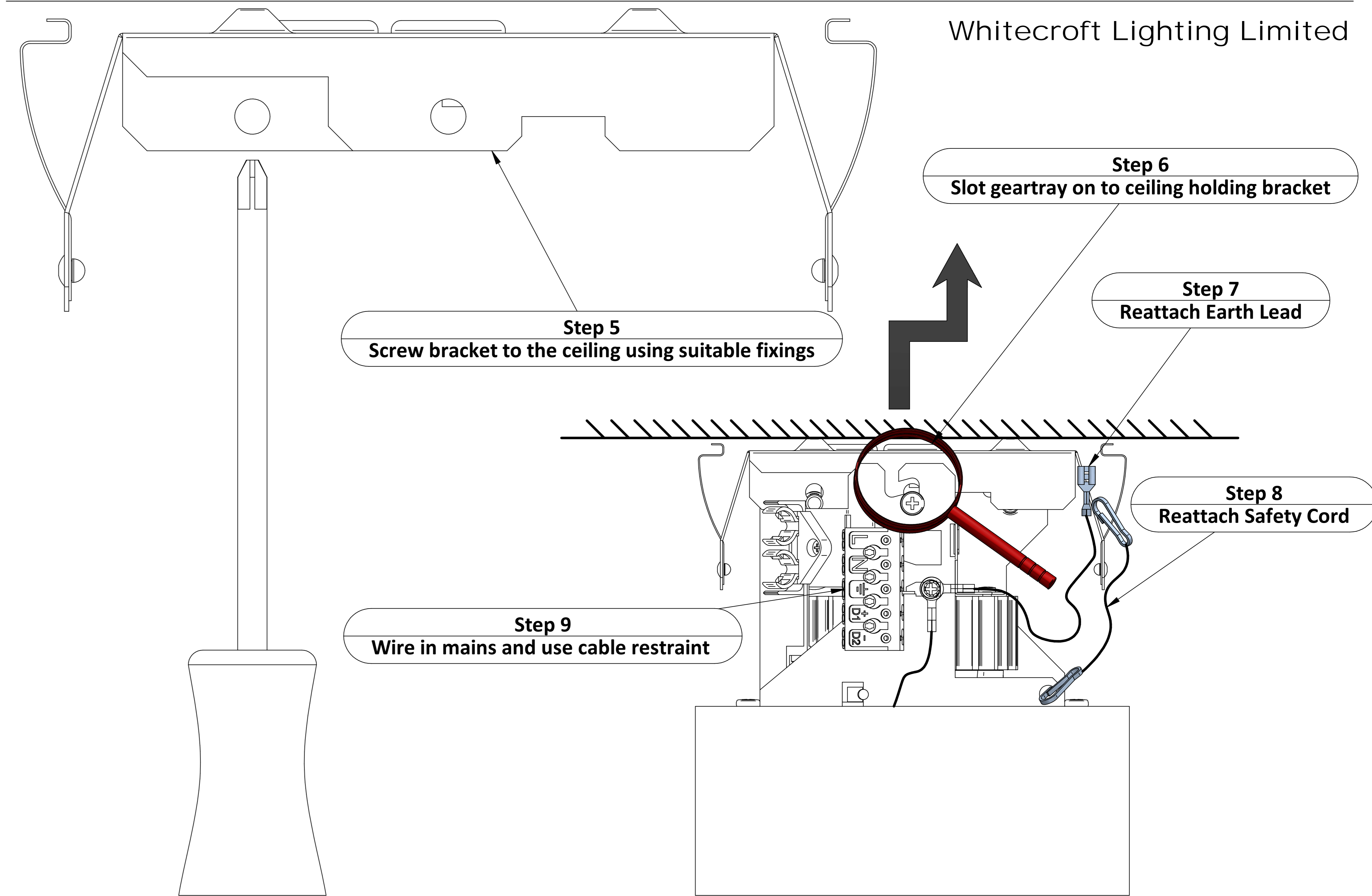

## If Suspending Product

