

SPECIFICATION

Materials	Acrylic Diffuser Polycarbonate back Gear Box (Metallic Silver or White RAL 9003) Aluminium Spun main body (Metallic Silver or White RAL 9003)		
Supply	240V	Operating temp	-5°C to 25°C
Power	550	2570lm 17.7W	3470lm 23.6W
	550 P/O	6390lm 46.3W	8100lm 60W
	750	6000lm 40.7W	8000lm 58W
	1000	10,000lm 67.6W	14,000lm 103.5
Connection	550 Terminal block 0.75mm ² to 2.5mm ²	750/1000	GST 6way plug
Ingress protection	IP20		

DIMENSIONS

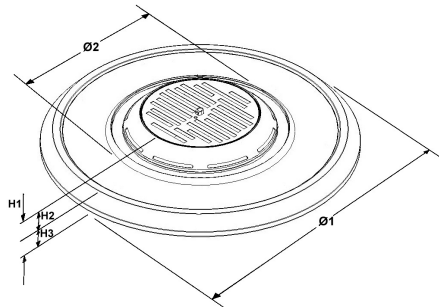

Version	Ø1	Ø2	H1	H2	H3	KG	KG(EM)
550mm	550	444	98	46	49	4.7	5.0
550mm Power Optic	550	444	98	46	49	4.8	5.1
750mm	750	444	98	46	49	6.7	7.0
1000mm	1000	444	98	46	49	10.2	10.5

GENERAL INFORMATION

- 1) A qualified electrician, in accordance with IEE wiring regulations should carry out connection to mains wiring.
- 2) Ensure that the rated voltage and frequency requirements are compatible with the available mains supply.
- 3) Do not carry out high voltage insulation test, i.e. 500/1000v this may damage internal components.
- 4) Access for connection of the emergency batteries is done by unscrewing the 3 fixings on top of the gear tray and connecting the batteries to the inverter. This is to be done when a power supply is connected.

TECHNICAL SUPPORT

Telephone: 0161 331 5700
E-mail: technical@whitecroftlight.com
<http://www.whitecroftlighting.com/>

Whitecroft
lighting

Oculus

Installation Instructions

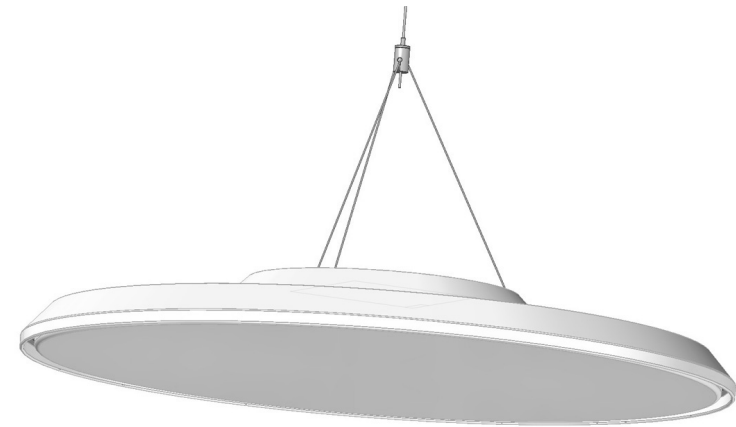

PK/OC/INSTLEAFLET

Revision 6 OCT 2020



Whitecroft Lighting Limited

Burlington Street, Ashton-under-Lyne, Lancashire OL7 0AX
Telephone +44 (0)870 5 087 087 Facsimile: +44 (0)870 5 084 210
www.whitecroftlighting.com

Registered No. 3848973 England

Registered Office: As above

Suspension

The suspension kit (sold separately) contains the following parts;

- 1 x Flanged cups
- 1 x Round cups
- 3 x 500mm single ball suspension cables
- 1 x 3,5 or 7 meter main suspension cable
- 1 x 4,6 or 8 meter safety suspension cable
- 1 x Cylindrical Tri clutch
- 1 x Cylindrical Tri collar
- 1 x Double Clutch

Thread the 3, 5 or 7 meter central suspension wire down through the round ceiling cup.

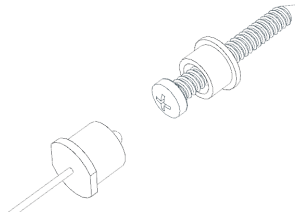

Screw the flanged ceiling cup into the drilled hole in the ceiling. Get the threaded round suspension cup and then screw the cup onto the fixed flange cups. Please use suitable ceiling fixings for suspending.

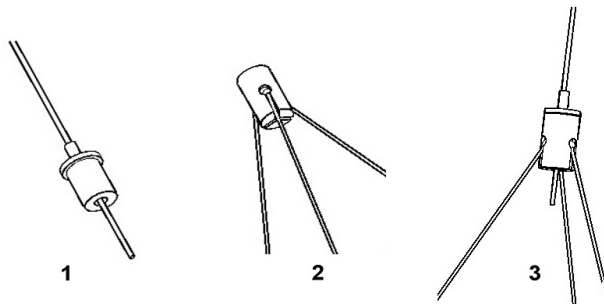

Thread the clutch assembly onto the suspended cable (1) at the desired height. Assemble the tri collar with the three small cables with the small ball ends slotted into place (2). Screw the Tri collar up onto the suspended clutch right the way onto the clutch thread to secure the small balls(3).

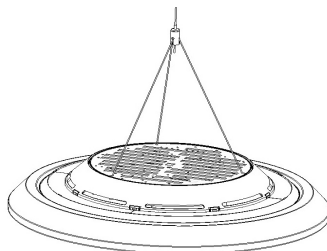

Hold the fitting up to the three suspension wires and thread each into the clutches through the 'U' shape slots in the gear cover lid. Adjust each one until the desired level is attained (min 400mm)
 1 The excess central suspension cable can now be snipped to length under the tri clutch (min

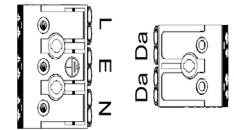
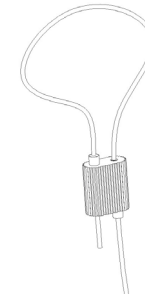
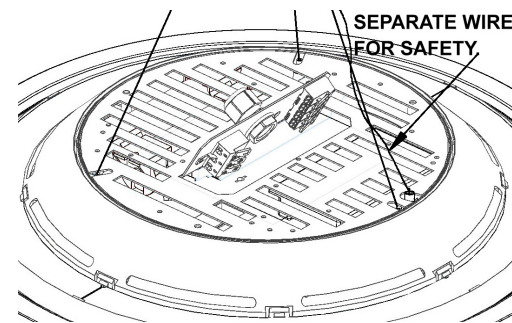

STANDARD DALI DIM

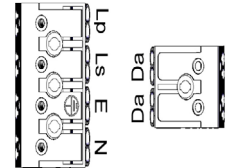

EMERGENCY DALI DIM

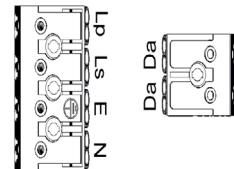

EMERGENCY COMEPS

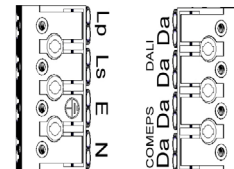

EMERGENCY COMEPS DALI DIM

*Please note: For Easytest (i.e. stand-alone self-test) do not wire DALI to the COMEPS coms'. For addressable dali systems the linking of the Comeps and Dali is required.

For added security the customer has the option of installing an additional safety suspension wire into a fourth clutch. This suspension wire (supplied with suspension kit) can then be run up to ceiling following the with existing suspension line (see above image, left) and looped into place with the supplied double clutch (see above image, right). THIS WIRE SHOULD NOT BE UNDER ANY TENSION.

Mains Connection

550mm Variants

On the 550 variants the terminal blocks are mounted on a flap which is folded up to expose them. Firstly unscrew the flap retaining screw and fold up to expose the terminal blocks. Unscrew the cable gland and screw back in position the other way around. The cable is guided through the cable gland and terminated in the two adjacent blocks as in the table right (use 60mm of striped cable) Fold the flap back down and secure with the retaining screw.

750/1000mm Variants

FOR NON-COMEPS OPTIONS

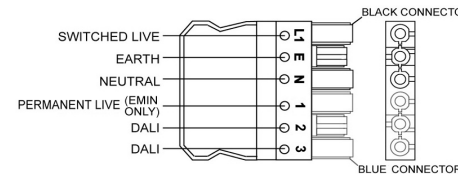

FOR COMEPS OPTIONS

- A) When using fully addressable system including sensors.
- 1, Wire DALI pair to the external plug as shown above.
 - 2, Remove screws and lift off gearbox cover.
 - 3, Add the link wires to the 4 way terminal block as shown below.
 - 4, Re-attach cover and fit plug to the socket.
- B) When using DALI broadcast sensor + separate emergency test system.
- 1, Wire DALI pair to the external plug as shown above.
 - 2, Remove screws and lift off gearbox cover.
 - 3, Wire COMEPS pair to the 2 terminals labelled DALI EM on the internal 4 way block shown below. Do not attach link cables.
 - 4, Re-attach cover and fit plug to the socket.

DIMMING DALI PRODUCT WITH COMEPS
 PUT LINKS WHEN YOU USE ADDRESSABLE SYSTEM

