

## GENERAL INFORMATION

- 1) A qualified electrician, in accordance with IEE wiring regulations should carry out connection to mains wiring.
- 2) This unit must be EARTHED.
- 3) Ensure that the rated voltage and frequency requirements are compatible with the available mains supply.
- 4) Cleaning of reflectors and lenses should be carried out using clean, soft and lint free cloths and anti-static cleaning fluid
- 5) Do not carry out high voltage insulation test, i.e. 500/1000v this may damage internal components.
- 6) The Emergency Lighting CNXEMKIT/EP Remote pack must be suitably positioned to avoid high temperatures.
- 7) Temperature range for the remote pack is 0 - 40°C.
- 8) All mains supply cables connected to CNXEMKIT/EP remote pack must be kept as short as possible and should be of a HAR approved heat resisting type.
- 9) The Emergency Lighting CNXEMKIT/EP remote pack is supplied with a 4 way mains plug which has screw type terminals suitable for cable of 0.5mm to 1.5mm CSA.
- 10) Supply cables and lamp circuit cables should be physically segregated, and all LED drive/indicator cabling kept as far away as possible from any other lamp wiring.



# Concert XL

## LED DALI EMPRO Emergency Kit

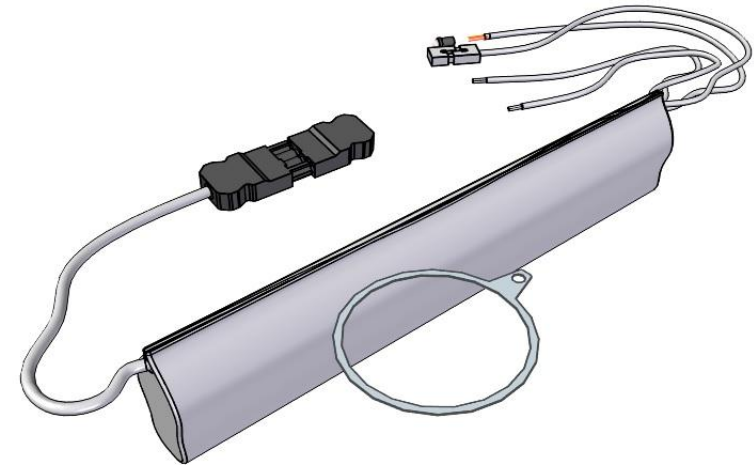

### Recessed LED Emergency Conversion Kit Installation Instructions

February 2014 - Rev A

**TECHNICAL SUPPORT**  
Telephone: 0161 331 5700  
E-mail: [technical@whitecroftlight.com](mailto:technical@whitecroftlight.com)  
[whitecroftlighting.com](http://whitecroftlighting.com)



**Whitecroft Lighting Limited**

Burlington Street, Ashton-under-Lyne, Lancashire OL7 0AX  
Telephone +44 (0)870 5 087 087 Facsimile: +44 (0)870 5 084 210

Registered No. 3848973 England

Registered Office: As above

## INSTALLATION DETAILS

1. Unpack all components and examine to ensure they are free from damage.

The package should include the following-

- 1 x EMIN Kit
- 1 x LED feature ring

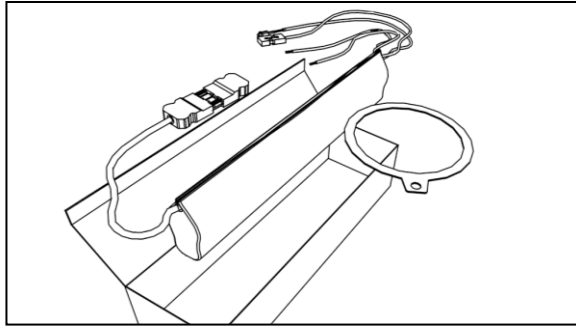

2. Use the dimension guides (fig.1, fig.2) to prepare the aperture for the luminaire to be mounted within.

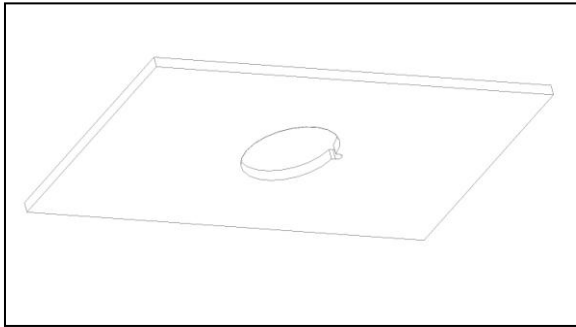

3. The feature ring can now be fitted to the luminaire. Rotate the yellow ceiling tile clamps to allow the ring to sit flush against the bezel (fig.3, fig.4)

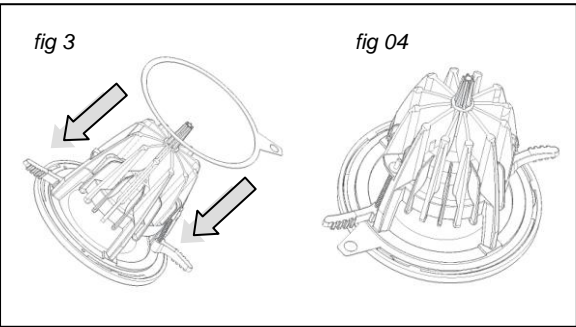

4. Release the covers as in fig 5 using a flat head terminal driver. Release the cable clamps and remove the prewired LED connections as shown in fig 6. To remove the clamps use a terminal driver to carefully lever the lug away from the gripping teeth.

The purple wires should remain connected.

NB the Dali connection does not need to be removed for any emergency options.

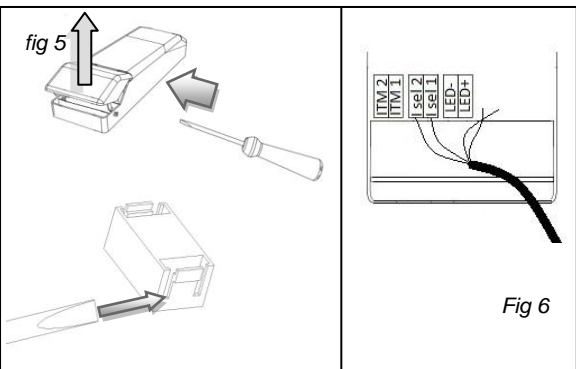

5. Take free red and black cables (Driver LED Output) attached to the emergency kit and secure them to the LED driver in the position shown in fig 7 (SEC position) please note that these terminations are polarity conscious. Next take the free brown and blue cables from the emergency kit and secure them to the LED driver as shown in fig 8, note these terminations are not polarity conscious, The driver cable clamps can now be pushed back into place.

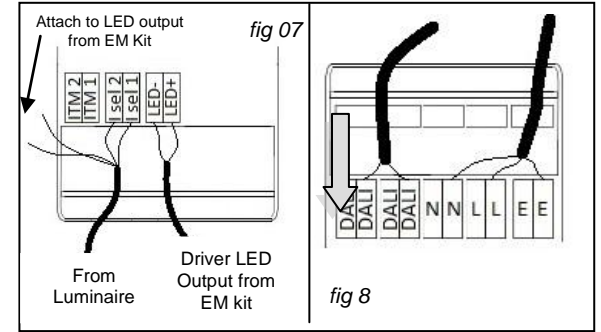

6. Locate the 2 x 2 way connectors fixed to the LED output cable from the emergency kit and disconnect the free connector by pulling them apart (see fig 9) Next take the 2 cables which were removed from the driver in point 4 and fix them into the terminations on the 2 way connector which was just removed, ensuring the red cable connects with the red cable from the emergency kit, please note that this termination is polarity conscious, (see fig 10.)

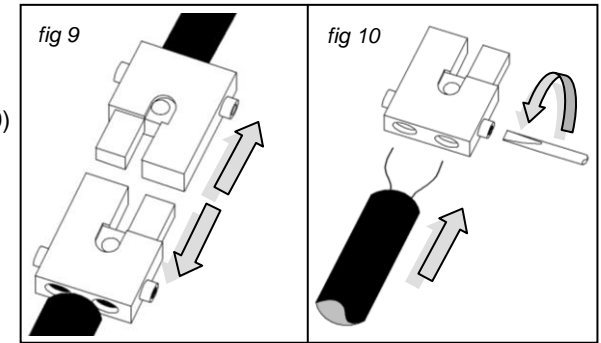

7. Disconnect the free 4 way connector from the emergency kit and remove the top cover (see fig 11) Ensure that the power supply is isolated, then bring the power supply cable through the prepared aperture in the ceiling and connect the corresponding wires (see wiring diagrams for more details) ensuring that the terminations are secure. Note the position of the earth terminal. Next fix the top cover of the connector back into position (see fig 12 for removal and assemble.) L1 = Switched Live

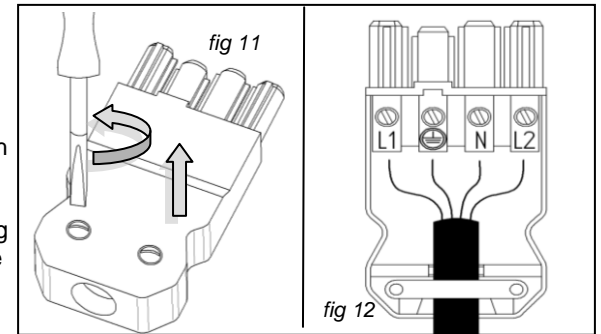

8. The emergency battery pack can now be connected, to access this open the emergency kit as shown fig 13. Then take the 2 connectors which are attached to the battery cells and connected them as shown in fig 14. Close the fireproof bag and secure the covers on the LED driver.

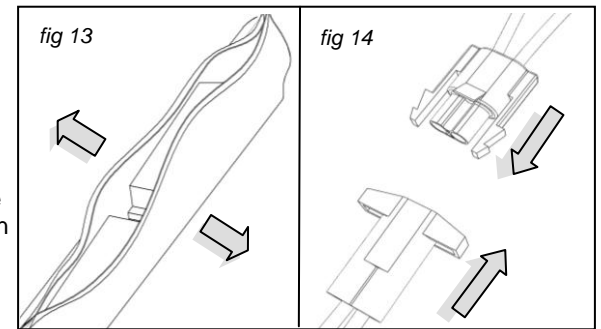

9. The charge indicator LED is to be removed from the collar it is contained in; this will pull off the small LED as in fig 15. Next push the emergency pack and driver through the prepared aperture in the ceiling, leaving the 2 way connector exposed, see fig 16.

The 2 x 2 way connectors should now be reconnected as shown in fig 18 as well as the mains lead.

10. Pull the emergency LED through the small pre cut aperture from behind the ceiling, locating it in the LED feature ring using the collar removed in step 9.

11. To install luminaire remove the bezel and slide the unit through the aperture (fig.19) Ensure that the small LED locates in the small hole in the feature ring. Turn the screws to secure in place.

Fit any attachments before replacing the bezel.

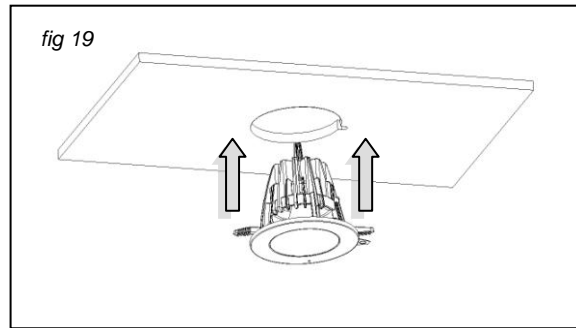
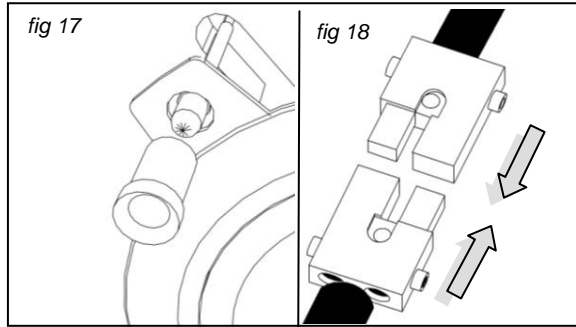
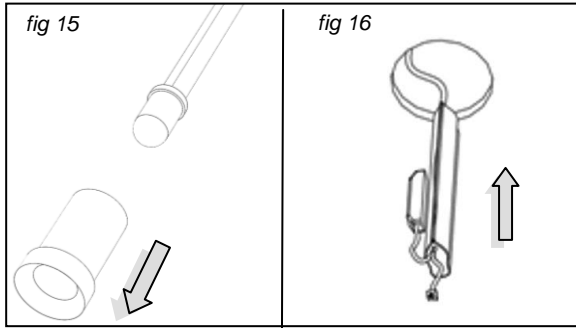

Please note: All images shown are for illustration purposes only and should be used as a reference guide.

## SPECIFICATION

Wiring complying with the relevant wiring regulations should include a permanent 220 to 240 volt 50Hz supply for battery charging and monitoring purposes.

The CNXEMKIT/EP remote pack should be connected to the normal mains supplies for a minimum of 24 hours before operating in emergency lighting mode because the battery requires a 24 hour charge before it will provide full rated duration (NB: battery duration performance will improve with the first two or three charge/discharge cycles).

All emergency lighting installations should be regularly tested and the results recorded. The appropriate test schedule is detailed in EN 50172.

fig.1

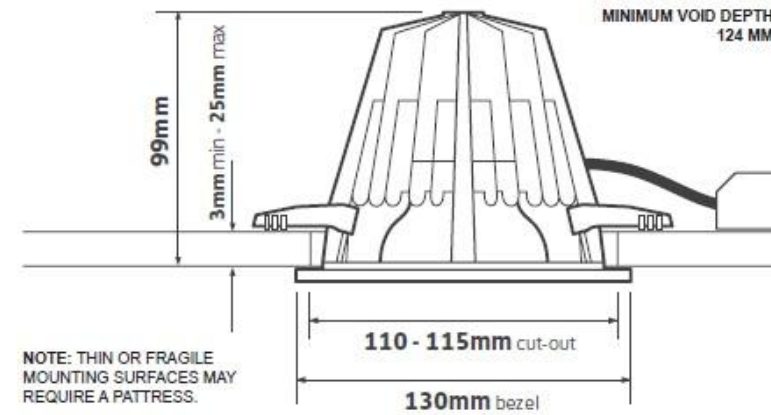

Allow adequate ventilation. Under no circumstances should the luminaire be covered with insulation matting, soundproofing or similar material.

## APERTURE CUT OUT DETAILS (Not to scale)

fig.2

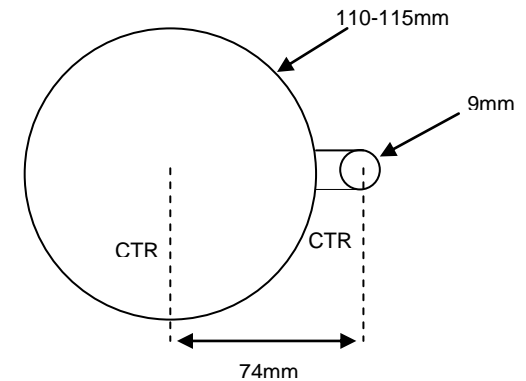

# WIRING DIAGRAMS

## FIXED OUTPUT LUMINAIRE

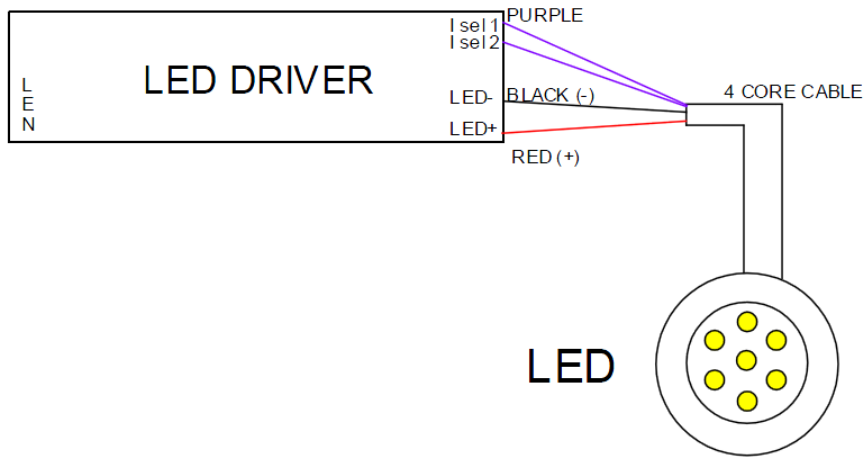

## DALI LUMINAIRE

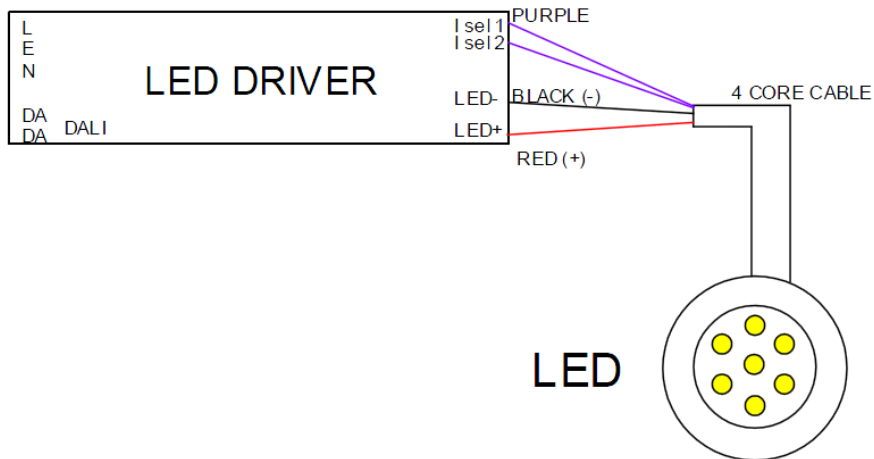

## FIXED OUTPUT LUMINAIRE With EMPRO

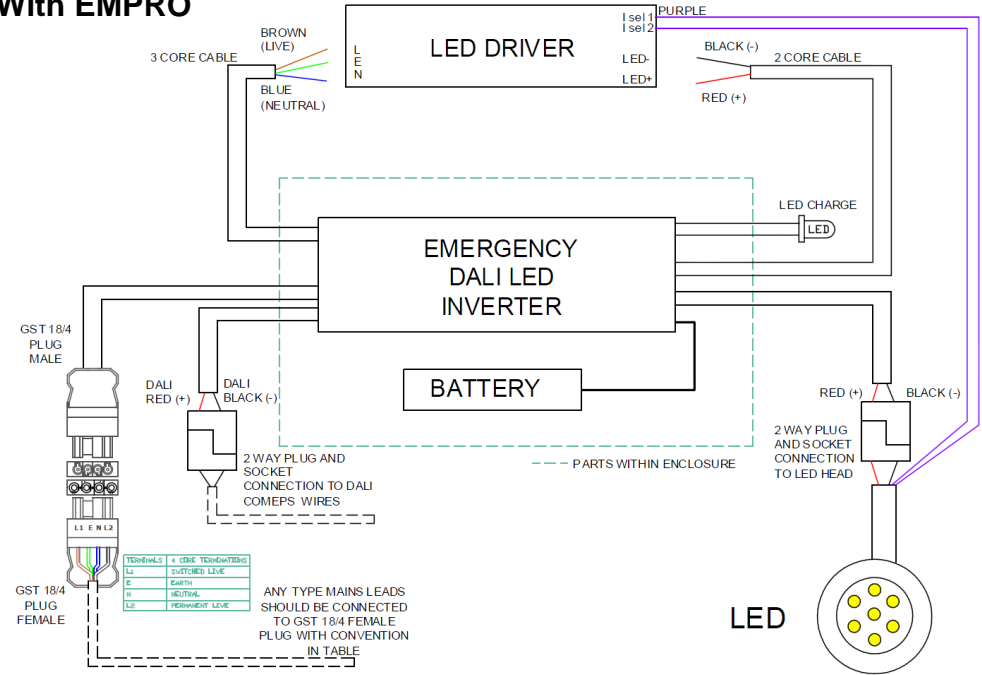

## DALI LUMINAIRE With EMPRO

