

General Information

1. A qualified electrician, in accordance with IET wiring regulations should carry out connection to mains wiring.
2. Luminaire must be isolated before commencing any necessary maintenance work or battery connection.
3. Ensure that the rated voltage and frequency requirements are compatible with the available mains supply.
4. Do not carry out high voltage insulation test, i.e. 500/1000v this may damage internal components.
5. The light source contained in the luminaire shall only be replaced by the manufacturer or a designated service agent or a suitably qualified person.
6. Batteries must only be replaced by a qualified electrician once they fail to meet the required duration.
7. Dali control cables must be double insulated & have an equivalent rating to the supply cable if applicable.
8. Ensure ceiling is of sufficient strength to support luminaire - Fit secondary suspension where necessary.
9. Observe ESD precautions during installation.
10. All luminaires must be EARTHED. (Excluding Class II luminaires).
11. Do not cover recessed luminaires with any thermally insulating materials.

Product Specification

Lamp Type	LED
LED Colour	3000K, 4000K
Control gear	DALI, Fixed Output
Emergency	Intergral 3hr / COMEPS
Finish	White
Materials	Steel, Polycarbonate
Weight	4.30kg
Supply	220-240V 50/60Hz
Cable entry	20mm
Connection	0.5-2.5mm ²
Ingress protection	IP54
Impact protection	N/A
Temperature range	0-35°C
Ceiling Compatibility	N/A
Suspension Detail	N/A

Full Installation Instructions

Scan QR code below:



Product Dimensions

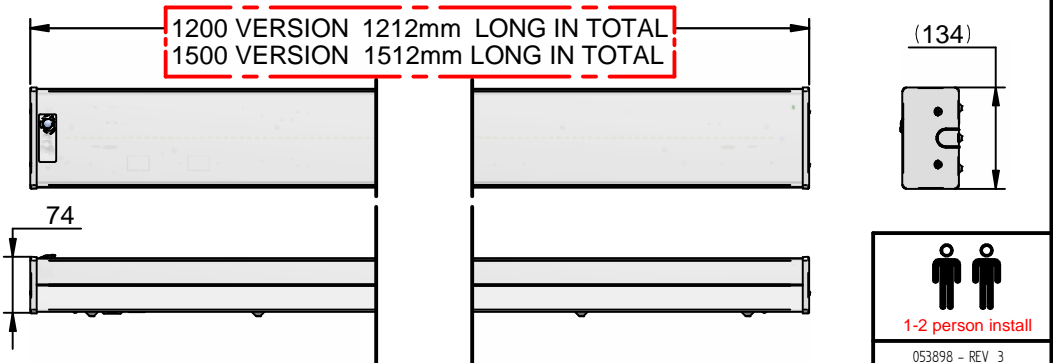

Whitcroft Lighting Limited
Burlington Street,
Ashton-under-Lyne,
Lancashire OL7 0AX

Technical Support
0161 330 6811
technical@whitcroftlighting.com
<http://www.whitcroftlighting.com>

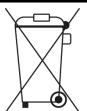

053898 - REV 3

General Information

1. A qualified electrician, in accordance with IET wiring regulations should carry out connection to mains wiring.
2. Luminaire must be isolated before commencing any necessary maintenance work or battery connection.
3. Ensure that the rated voltage and frequency requirements are compatible with the available mains supply.
4. Do not carry out high voltage insulation test, i.e. 500/1000v this may damage internal components.
5. The light source contained in the luminaire shall only be replaced by the manufacturer or a designated service agent or a suitably qualified person.
6. Batteries must only be replaced by a qualified electrician once they fail to meet the required duration.
7. Dali control cables must be double insulated & have an equivalent rating to the supply cable if applicable.
8. Ensure ceiling is of sufficient strength to support luminaire - Fit secondary suspension where necessary.
9. Observe ESD precautions during installation.
10. All luminaires must be EARTHED.(Excluding Class II luminaires).
11. Do not cover recessed luminaires with any thermally insulating materials.
12. Do not use the wire suspension to raise or lower the luminaire. (See full instructions for further details.)

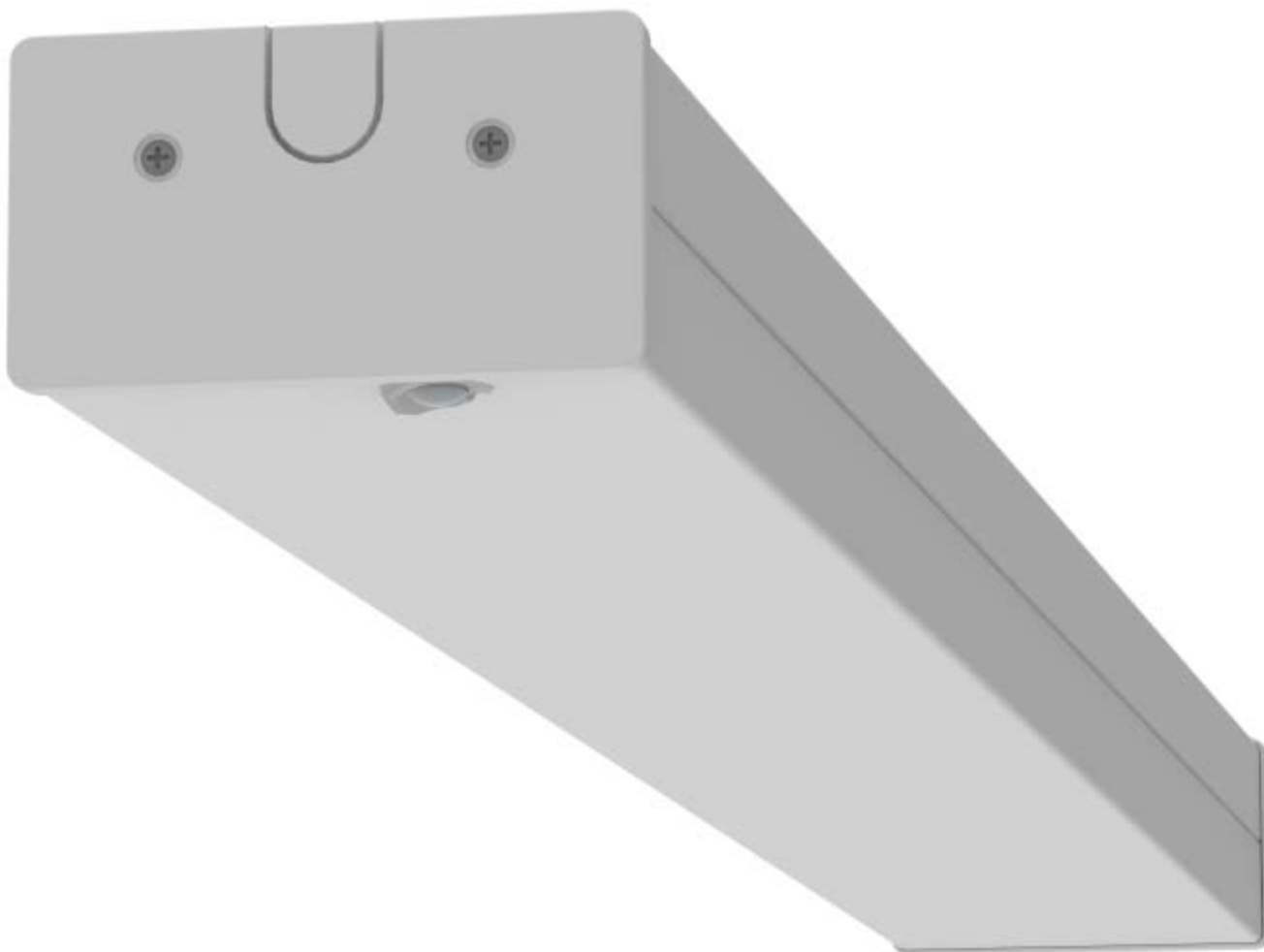

1-2 person install

053898 - REV 3

Whitecroft Lighting Limited
Burlington Street,
Ashton-under-Lyne,
Lancashire OL7 0AX

Technical Support
0161 330 6811
technical@whitecroftlight.com
<http://www.whitecroftlighting.com>



① REMOVE PACKAGING AND INSPECT PRODUCT FOR ANY DAMAGE.

② MOUNTING & CABLE ENTRY DETAILS BELOW.

RANGE FIXING CENTER DETAILS		
PRODUCT VERSION	A	B
1200mm	610mm	301mm
1500mm	610mm	445mm

CABLE ENTRY DETAILS

**NOTE:- 20MM CABLE ENTRY
(REFER TO STEP 09 FOR GROMMET
PIERCING DETAILS).**

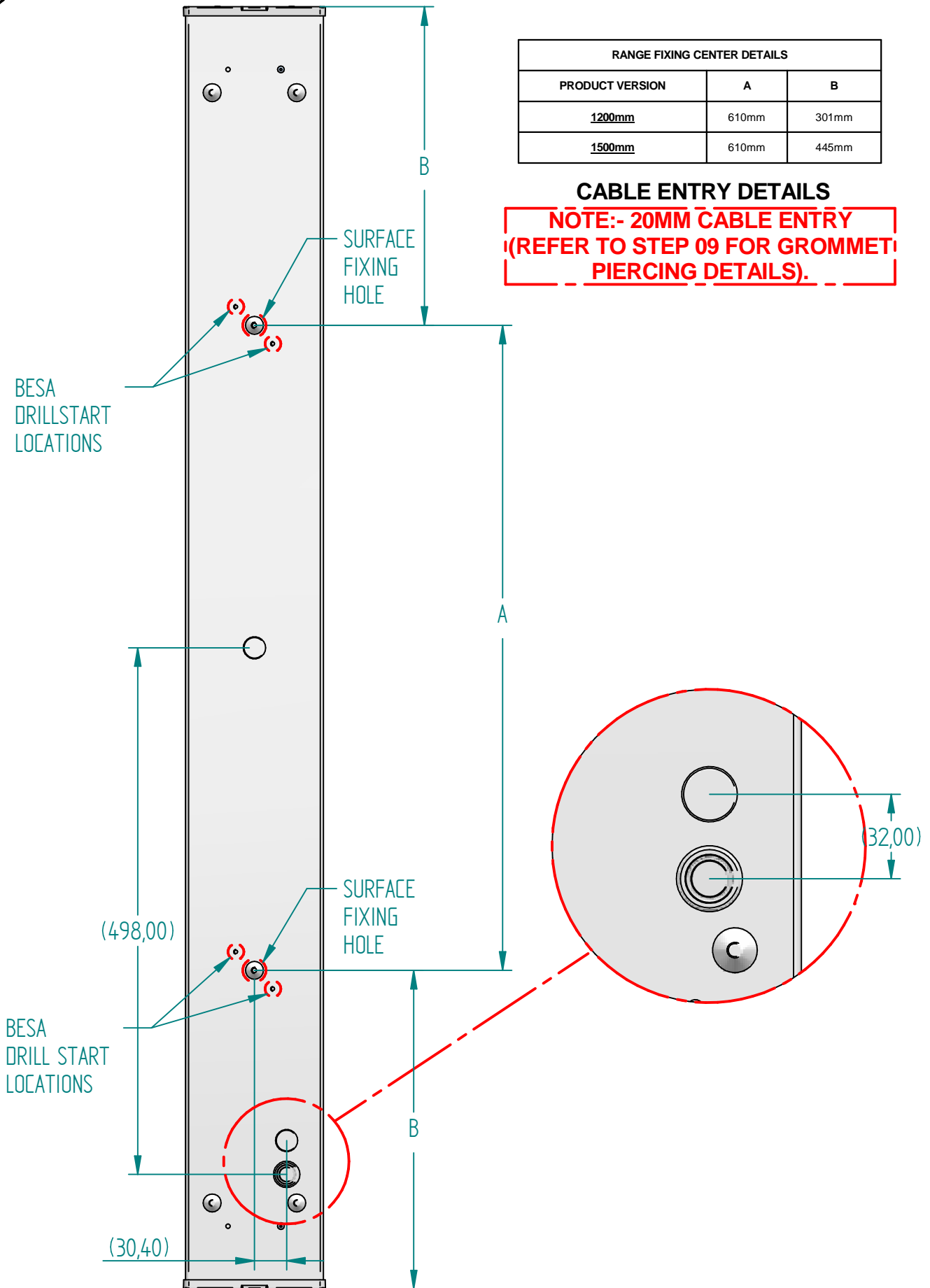

- ③ SEE STEP 1 FOR MOUNTING & CABLE ENTRY DETAILS.
- ④ REMOVE END CAP BY LOOSENING THE SCREWS, REPEAT THIS STEP FOR THE OTHER SIDE.

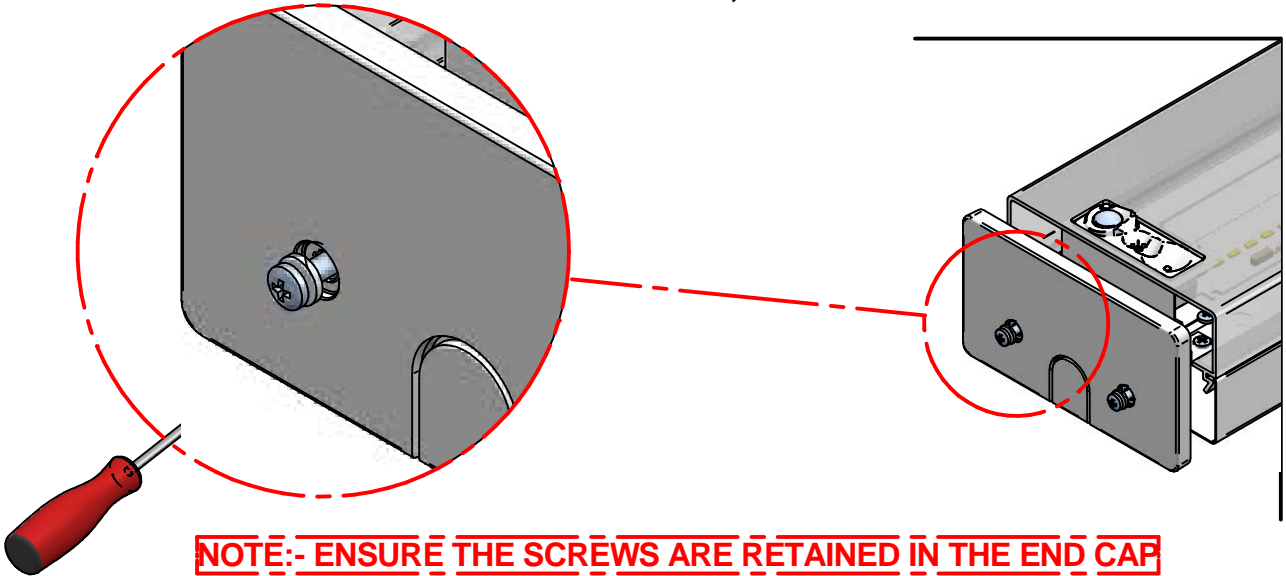

NOTE:- ENSURE THE SCREWS ARE RETAINED IN THE END CAP

- ⑤ REMOVE DIFFUSER FROM THE BODY BY FOLLOWING THE INSTRUCTIONS BELOW.

PUSH IN THE AREAS HIGHLIGHTED

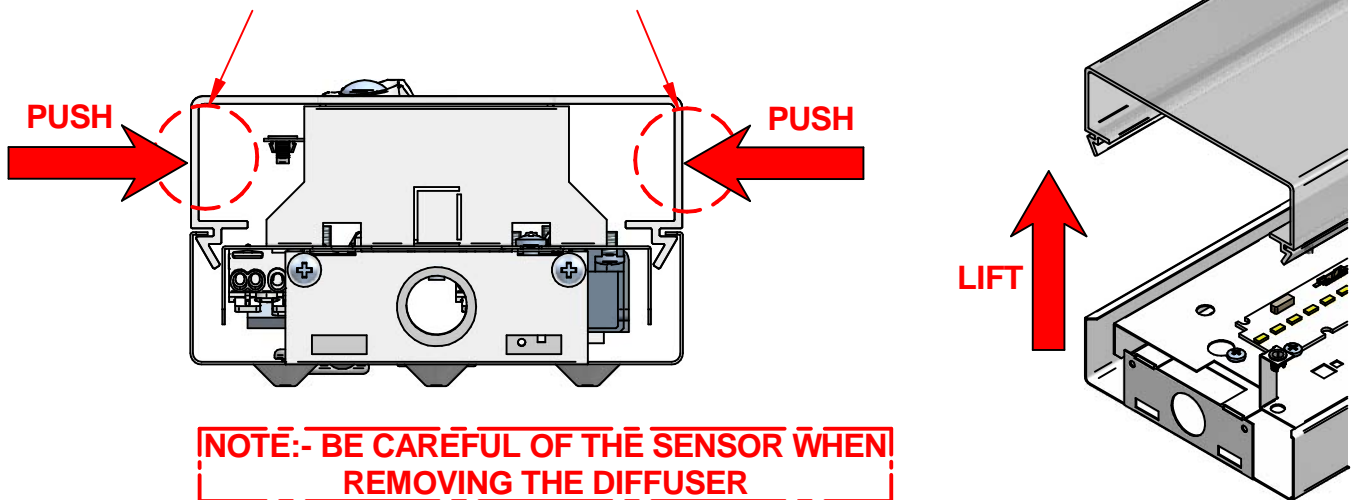

NOTE:- BE CAREFUL OF THE SENSOR WHEN REMOVING THE DIFFUSER

- ⑥ LOOSEN THE SCREWS ON BOTH SIDES OF THE GEAR TRAY & SLIDE THE GEAR TRAY OUT TO GAIN ACCESS TO THE SAFETY CORDS AND EARTH LEAD.

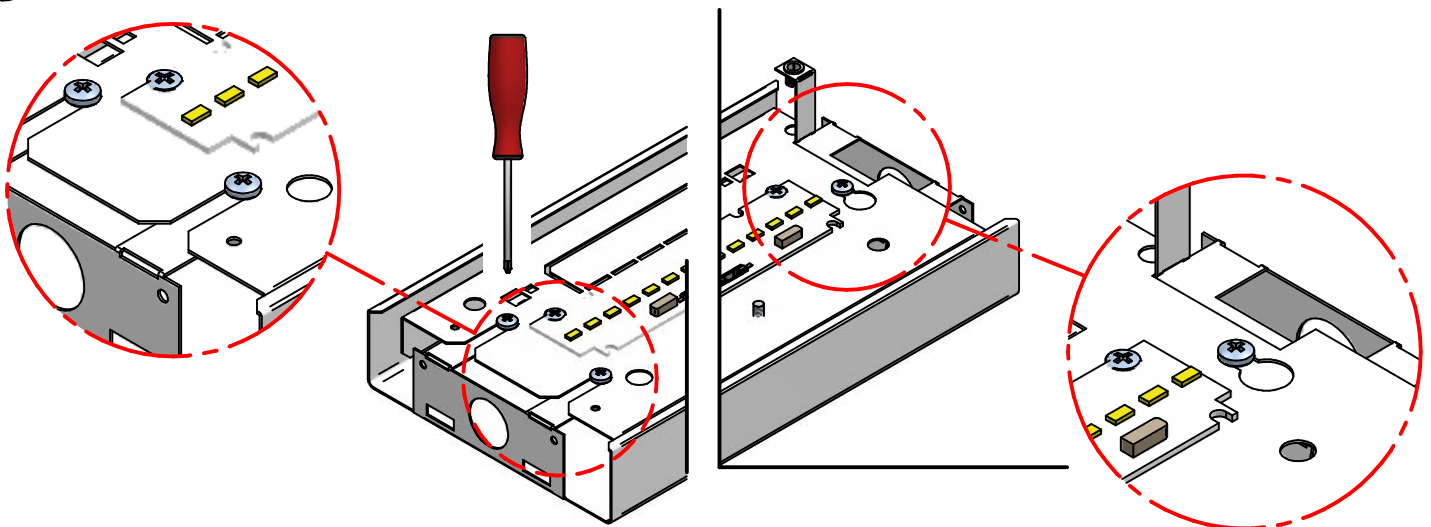

7 UNCLIP SAFETY CORDS AND DETACH EARTH LEAD

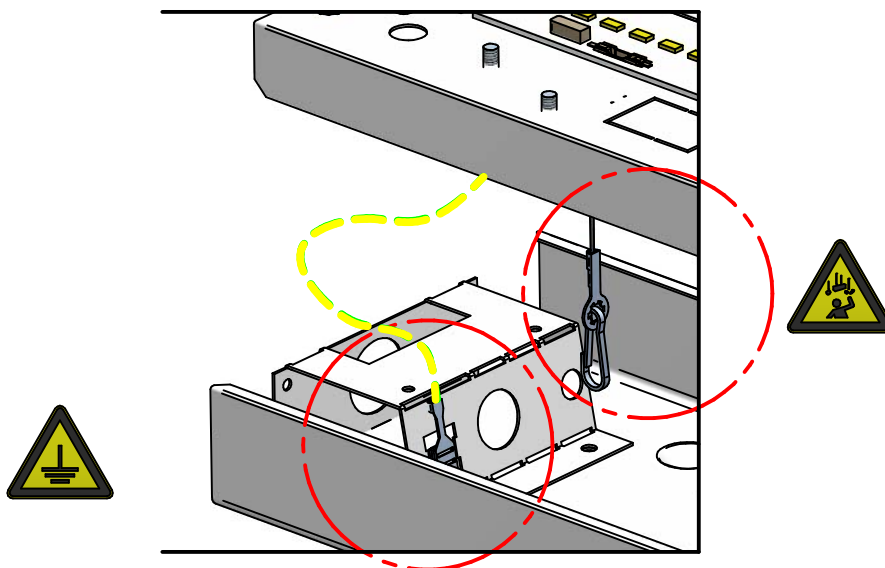

8 FOR BESA FITTING ONLY. USING DRILL STARTS AS A GUIDE. DRILL 4 X 5MM HOLES. USE SURFACE FIXING HOLE AS A DRILL START FOR A 20MM HOLE. REFER TO STEP 2 FOR LOCATIONS

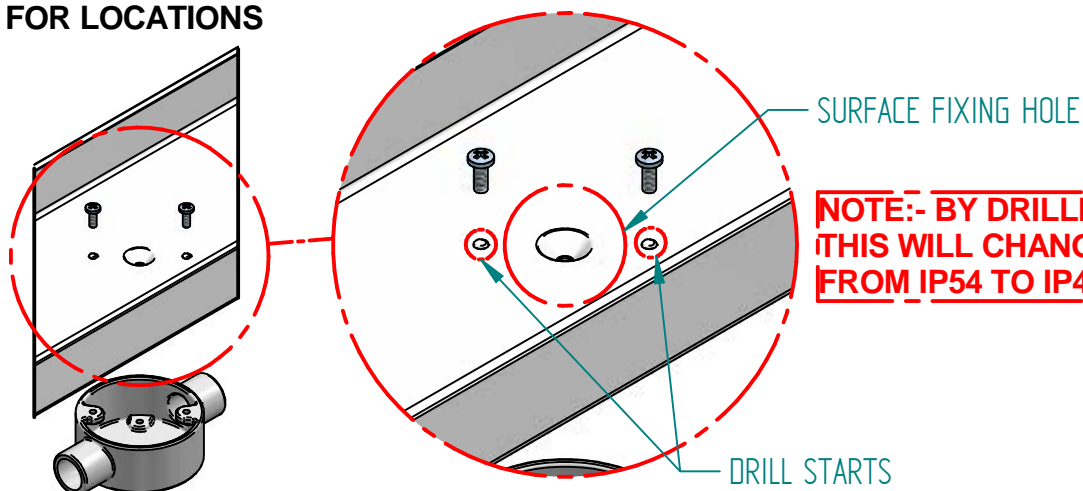

9 BEFORE ROUTING THE CABLE, PIERCE THE CABLE GROMMET WITH A ROUND TIPPED SCREWDRIVER.

NOTE:- THE GROMMET SHOULD HAVE NO GAPS TO RETAIN THE IP RATING OF IP 54

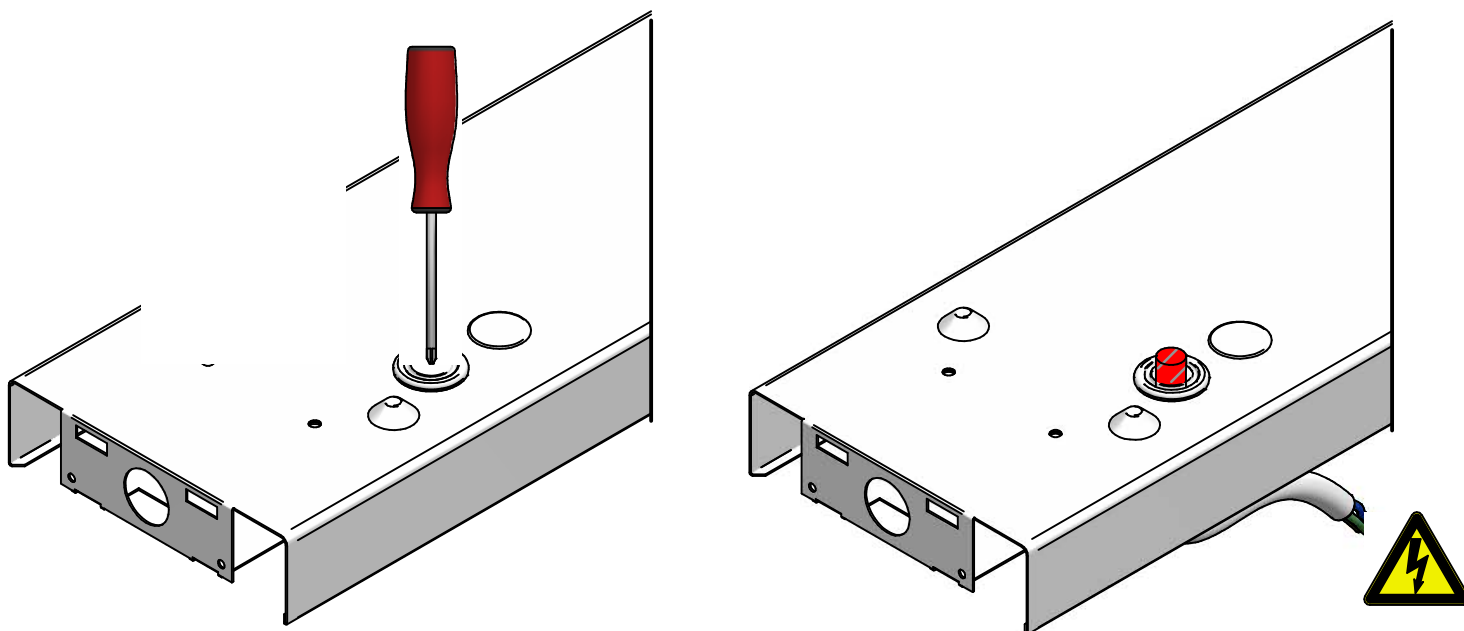

- ⑩ MOUNT THE BODY USING THE DETAILS IN STEP 1 & ROUTE THE CABLE

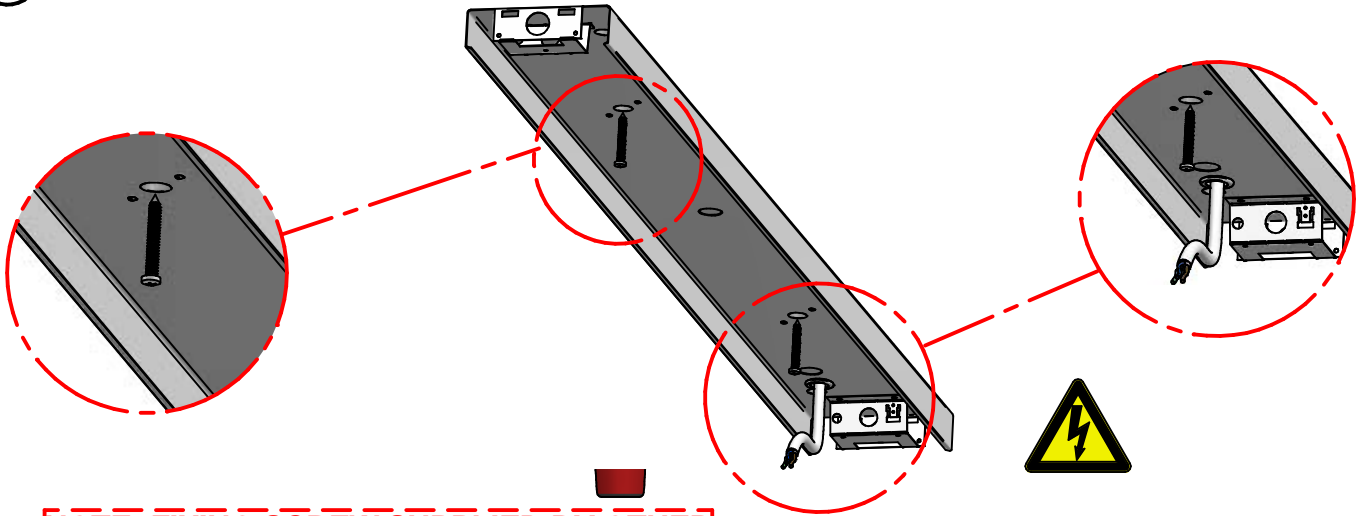

NOTE: FIXING SCREW SUPPLIED BY OTHER

- ⑪ FOR CONDUIT / STUFFING GLAND ENTRY ONLY. REMOVE KNOCKOUT FROM END CAP.

NOTE:- STUFFING GLAND SUPPLIED BY OTHER

**CUT THE HIGHLIGHTED
AREA OUT OF THE END CAP**

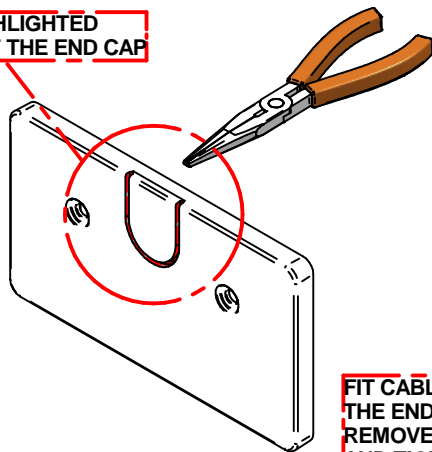

**FIT CABLE/STUFFING GLAND AFTER
THE ENDCAP KNOCKOUT HAS BEEN
REMOVED. SLIDE THE ENDCAP IN PLACE
AND TIGHTEN THE CABLE/STUFFING GLAND**

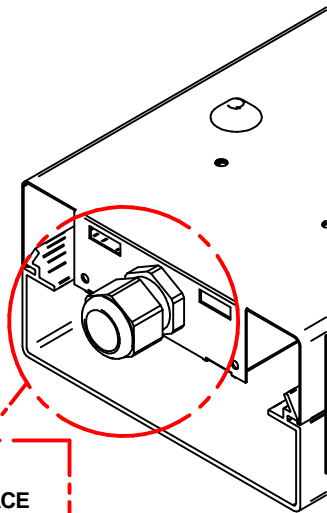

- ⑫ HANG THE GEAR TRAY TO THE BODY BY CLIPPING THE SAFETY CORDS IN PLACE, TO ALLOW EASY WIRING.

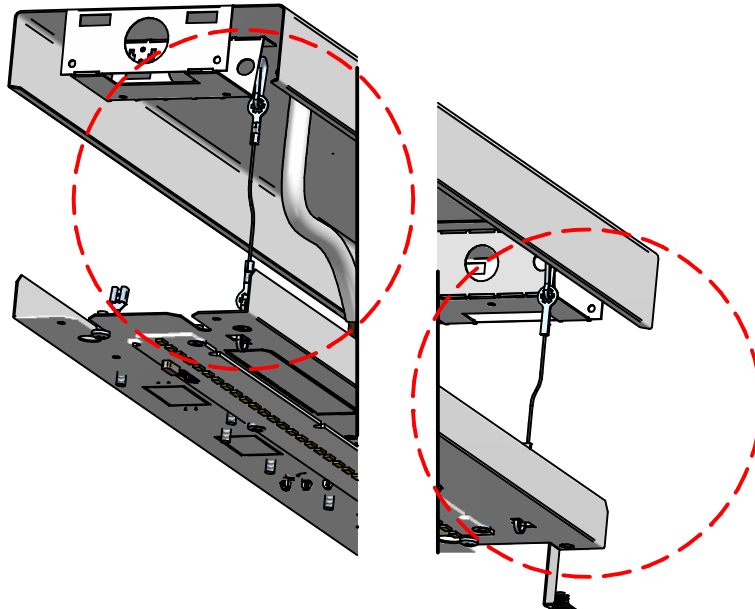

13 MAKE REQUIRED CONNECTIONS, SEE TERMINAL BLOCK DIAGRAMS. USE CABLE TIE TO RESTRAIN CABLES WITHIN THE PRODUCT.

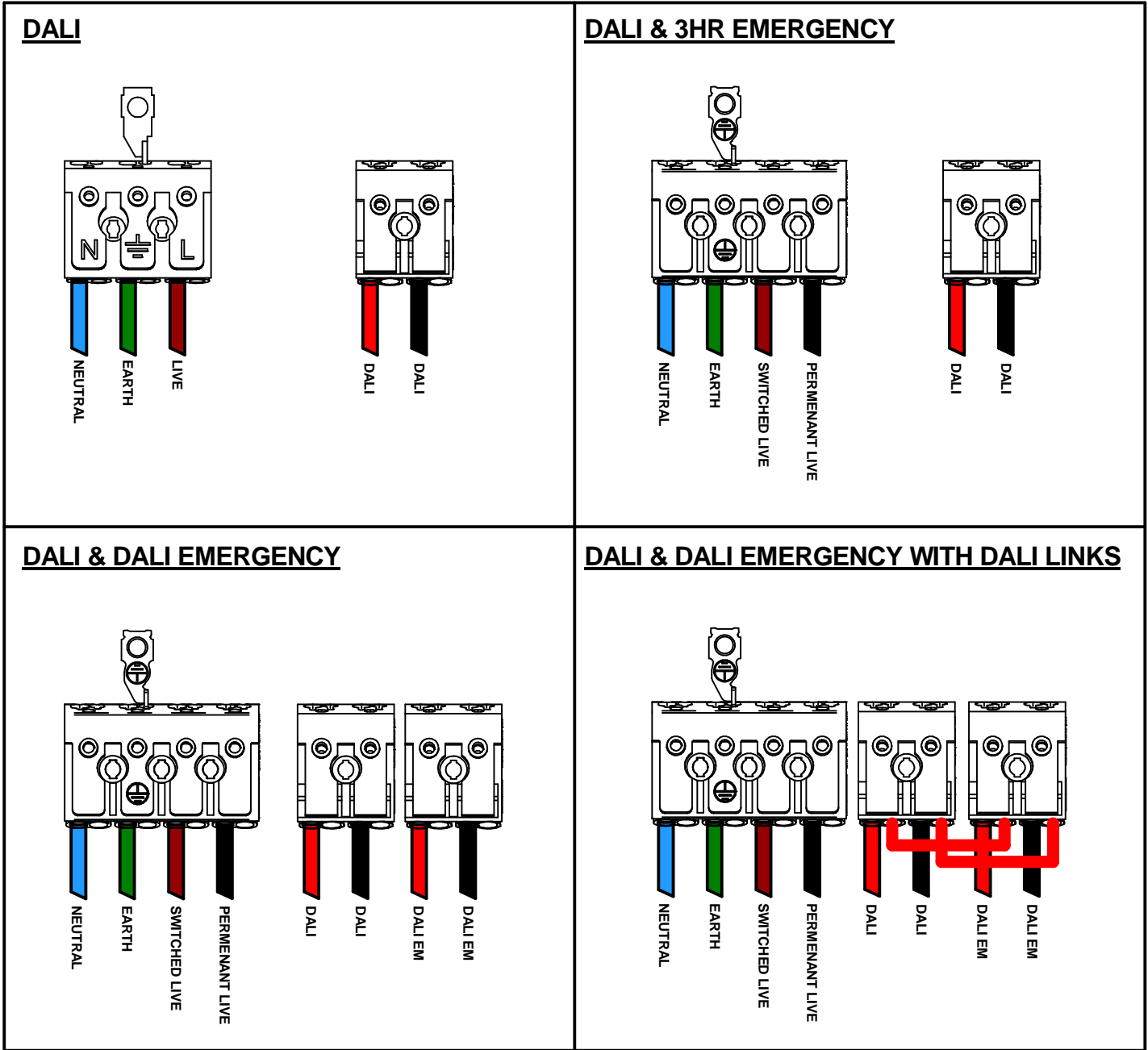

14 CONNECT EMERGENCY BATTERY IF REQUIRED

NOTE: FOR MAINTANENCE REPEAT STEPS 4-7 TO GAIN ACCESS TO THE BATTERY!

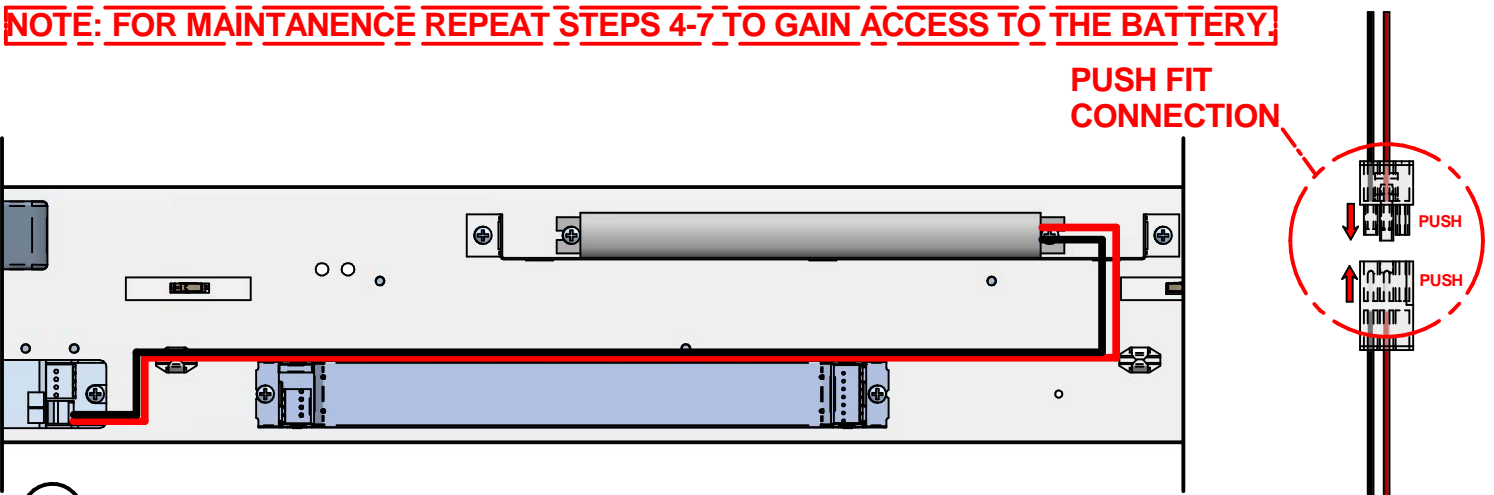

15 TO RE-ASSEMBLE REPEAT STAGES 4-7 IN REVERSE.

Emergency Luminaire

Maintenance, Commissioning & Fault Finding Guide



BATTERY STORAGE/CARE DETAILS

Optimal storage conditions (when not in service and batteries disconnected)

- NiCd +5°C to 25°C (6 months onsite maximum)
- NiMh +5°C to 25°C (3 months onsite maximum)
- LiFEP04 +5°C to 25°C (6 months onsite maximum)

Old batteries must be handled and disposed of by specialist disposal experts. Under no circumstances should they be pierced or incinerated.

Do not put the luminaire into emergency mode until the batteries are fully charged

MAIN CAUSES FOR PREMATURE BATTERY FAILURE:

- 1) Over cycling of batteries for example caused by an unstable mains supply. Batteries are designed to carry out 3 – 4 full discharges per year. Over cycling will reduce the capacity and hence life.
- 2) Leaving connected batteries in a discharged state (maximum 2 weeks).
- 3) High ambient temperatures (greater than the ambient specified by Whitecroft lighting)
- 4) Repeated partial discharging and recharging of batteries (memory effect)

EMERGENCY SUPPLIES

Power to energise emergency luminaires can come from integral batteries within the luminaire (self-contained) or from a remote Central Battery system or Static Inverter. This power supply is intended to energise the emergency circuit within any emergency luminaire upon failure of the normal supply.

Integral battery emergency luminaires indicate 'batteries are charging' generally by use of an indicator LED mounted in a visible location on the luminaire. When the indicator LED is solid green, the batteries are charging.

Emergency luminaires generally have internal supply connections: Permanent Live (orange), Switched Live (brown), Neutral (blue), and Earth (green/yellow).

TESTING REGIME

As detailed in BSEN50172:2004 (BS5266-8:2004)

- Monthly function test (30s) to check luminaires are functioning correctly (unless detailed differently in commissioning procedure)
- Annually full duration test to check the luminaires are functioning correctly and meet their full duration
- Emergency testing results must be documented and be available for inspection.

FAULT FINDING

Inspection / fault finding work must be carried out by a suitably electrically qualified person.

Initial checks must include continuity of fuses and integrity of internal/external wiring.

Please read BATTERY STORAGE/CARE details in this leaflet before continuing.

CAUTION: Even if the power supply to the emergency luminaire may be disconnected, there may still be high voltages inside the fitting. Disconnect batteries when maintaining internal wiring.

- A. LED indicator non-operational and does not work in Emergency mode.
 1. Check that the permanent 230v supply is present in the luminaire.
 2. Check the batteries are properly connected.
 3. Replace the batteries with known working units.
 4. Replace the inverter ensuring you change it 'wire for wire'.
 5. If the luminaire still does not function please call Whitecroft Technical.
- B. Luminaire functions in Emergency mode but will not function in Standard mode.
 1. Check that the Switched Live is present.
 2. Check that the Switched and Permanent Supplies are correctly connected.
 3. Check that there is 230v at the 'Live Out' terminal of the emergency inverter.
 4. If the luminaire still does not function please call Whitecroft Technical.
- C. LED indicator illuminated but luminaire does not work in Emergency mode.
 1. Check light engines in emergency circuit are working
 2. Replace the batteries with known working units.
 3. Replace the inverter ensuring you change it 'wire for wire'.
 4. If the luminaire still does not function please call Whitecroft Technical.
- D. LED indicator not illuminated but luminaire functions in all other respects.
 1. Check the cable to the LED indicator; make sure it is properly terminated and has not been trapped or cut.
 2. Replace the LED indicator with a known working one.
 3. Replace the inverter ensuring you change it 'wire for wire'.
 4. If the luminaire still does not function please call Whitecroft Technical.
- E. Luminaire will not last 3 hour duration test.
 1. Check that the batteries have been charged for at least 24 to fully charge
 2. Check that the Switched and Permanent Supplies are correctly connected.
 3. Replace the batteries with known working units.
 4. Replace the inverter ensuring you change it 'wire for wire'.
 5. If the luminaire still does not function please call Whitecroft Technical.

EMERGENCY LUMINAIRE COMMISSIONING

Battery activation

- For new NiCd, NiMh & LiFEP04 batteries activation of the cell is required to ensure specified design life.
- If the emergency luminaire does not pass the initial 3hr duration test a further full charge and discharge cycle may be required to activate the battery chemistry.

PROCEDURE

STANDARD EMERGENCY

1. Connect the battery once a stable mains supply is present
2. Allow the battery to charge for a period of 24hrs
3. Perform a full manual discharge test (minimum 3 hrs.)
4. If the emergency luminaire does not pass the initial 3hr duration test a further full charge and duration test (this test can be used as the scheduled EM test)
5. If the luminaire does not pass 3 hour test contact Whitecroft Technical for assistance.

EASY-TEST/SELF-TEST

1. Connect the battery once a stable mains supply is present
2. Allow the emergency luminaire to complete its self-commissioning phase which charges the battery for 24hrs, followed by a 3hr duration test. If the luminaire successfully completes this test, the indicator LED will be solid green
3. If the emergency luminaire does not pass the initial 3hr duration test, allow the battery to charge a further 24hrs and then do a manual 3hr duration test
4. If the luminaire fails this duration test then contact Whitecroft Technical for assistance

DALI TEST

1. Connect the battery once a stable mains supply is present
2. Allow the emergency luminaire to complete its self-commissioning phase which charges the battery for 24hrs, followed by a 3hr duration test. If the luminaire successfully completes this test, the indicator LED will be solid green OR if a DALI bus is connected and the luminaire has been commissioned the self-commissioning duration test can be stopped and a scheduled duration test can be performed using DALI commands.
3. If the emergency luminaire does not pass the 3hr duration test, allow the battery to charge a further 24hrs and then do a manual 3hr duration test
4. If the luminaire fails this duration test then contact Whitecroft Technical for assistance.

EMERGENCY COMEPS DALI TEST

Application

Low profile emergency lighting module with DALI interface and automatic testing facility to cover 3 hour duration operating from batteries. DALI interface terminals are provided to allow control and monitoring via a separate controller. With no DALI bus connected the unit operates in self-test mode with testing being conducted on a weekly functional and 52 week duration basis with adaptive duration testing feature to minimise risk. Fitted with the unique easy addressing feature which uses the LED to indicate the DALI address during commissioning.

Monitoring

DALI interface for controlled monitoring and reporting. During operation the battery, lamp and charge conditions are monitored along with functional and duration testing. In the event of failure the bi-coloured LED will indicate the nature of the fault. This it will continue to do until the fault has been remedied. The testing regime will then continue.

Testing

When a DALI bus is not connected or when a command has not been received the COMEPS will operate in the self testing mode and will conduct tests in accordance with the default times stored in the EEPROM. However it should be noted that in this case the delay time is set as default zero and all units could test at the same time. Test times can be changed with a command over the DALI bus.

Addressing

The COMEPS includes the easy addressing system which allows addressing and identification by using the bi-colour LED in conjunction with the COMEPS ADDRESS tool. Binary address codes given by the LED can be simply converted to the DALI addresses 0 to 63. For single handed addressing using this method it is necessary to send a broadcast ident command every 3 to 9 seconds. During this command the main fluorescent lamp will be switched off and the LED will flash the 6 bit binary address preceded by a 3 second start indication period.

Functional test

The time of day and frequency of the 30 seconds function test can be set by the DALI controller. If the COMEPS unit is not connected to a DALI bus or has not received a DALI command the test will default to 30 seconds duration on a weekly basis.

Duration test

Test times can be set by the DALI controller. If the COMEPS unit is not connected to a DALI bus or has not received a DALI command the test will be conducted every 52 weeks.

Prolong time

Prolong time can be set by the DALI controller. This is the delay time between return of the mains supply and the end of the emergency operation. The default prolong time is set as 0 minutes as specified within the DALI standard.

Battery

Recommended charge time is min. 24h. Battery should be fully charged before any emergency tests are performed.

STATUS INDICATION – TRIDONIC INVERTER

LED	STATUS
Permanent green	System OK
Fast flashing green	Functional test underway
Slow flashing green	Commissioning/Duration test underway
Permanent red	Lamp fault
Fast flashing red	Charging fault
Slow flashing red	Battery fault
Double pulsing green	Inhibit mode
Off	Loss of mains/battery supply

STATUS INDICATION – ELP INVERTER

LED	STATUS
Permanent green	System OK
Fast flashing green	Functional test underway
Slow flashing green	Commissioning/Duration test underway
Permanent red	Lamp/LED fault
Fast flashing red	Charging fault
Slow flashing red	Battery fault
Double pulsing green	Inhibit mode
Green with double off pulse	Rest mode
Alternate green/red flash	Identification Mode
Off	Loss of mains/battery supply

STATUS INDICATION – MACKWELL INVERTER

LED	STATUS
Permanent green	System OK
Fast flashing green	Functional test underway
Slow flashing green	Commissioning/Duration test underway
10 second green blink	Standby mode
Fast flashing red	Lamp/LED fault
Slow flashing red	Battery/Charging fault
Off	Loss of mains/battery supply

DALI LUMINAIRE CONNECTIONS FOR COMEPS AND DALI LUMINAIRE

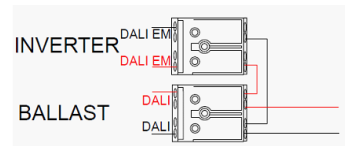

Note: It is imperative to add the links shown below if using DALI dimming and emergency test on the same addressable control circuit.

ORGANIC RESPONSE LUMINAIRE WITH COMEPS (DALI) LUMINAIRE CONNECTIONS

The luminaire is supplied with terminal connections for both the COMEPS inverter and Organic Response node. The Organic response terminal are supplied with the connections blocked to stop inadvertent connection. If the luminaire is to be used for emergency reporting on the Organic Response Portal system, then the terminations should be unblocked and connected as below.

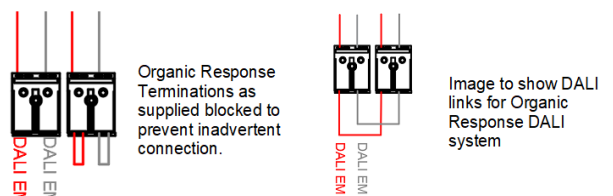

Application

Whitecroft Easytest is an intelligent testing system, which can monitor and test self-contained emergency lighting luminaires.

The system tests luminaires in line with current legislation for self-contained non-maintained emergency applications with battery duration up to 3 hours.

Intelligence

The easytest unit is a stand-alone intelligent module, which can be integrated into virtually any Whitecroft emergency luminaire.

Each intelligent luminaire has EITHER a bi-coloured LED OR TWO LED's to indicate unit 'on test' or 'failure' diagnostic information in addition to 'battery charging'.

Monitoring

During operation the battery, lamp and charge conditions are monitored along with functional and duration testing.

In the event of failure the LED (s) will indicate the nature of the fault until the fault has been remedied. The testing regime will then continue.

AUTOMATIC TESTING

Commissioning Test

A full commissioning test is carried out automatically after permanent connection of the supply. The easy commissioning feature will set the initial test day and time to ensure random testing of units.

Functional Test

Functional tests are carried out for 30 seconds on a weekly basis.

Duration Test

A full duration test is carried out yearly to check the capacity of the batteries.

STATUS INDICATION (Standard LED configurations)				
Single Bi-colour LED		STA TUS	Two separate LED's	
GREEN	RED		GREEN	AMBER
ON		System OK	ON	OFF
FLASHING		Functional test underway	ON	OFF
	ON	Lamp fault	ON	FLASHING
	SLOW FLASH	Battery fault	OFF	FLASHING
	FAST FLASH	Charging fault	OFF	FLASHING

NOTE : IEC 60073 recommends that the charge indicator LED should be Green to indicate System OK. The above table conforms to those recommendations.

It is possible to reverse the bi-colour LED connections to swap Green and Red indications and it is also possible to have an alternative Red + Amber LED pair for compatibility with earlier product.

WIRE ROPE SUSPENSION

Installation of Wire Rope Suspension System of Luminaires

Whitecroft Lighting luminaires must be installed in accordance with the relevant installation instruction and as guidance the latest version of BSRIA Code of Practice 22 - Wire Rope Suspension Systems.

Do not use the wire suspension to raise or lower the luminaire during installation as this may result in damage to the clutch mechanism.

The clutch should only be adjusted when supported and under no mechanical load.

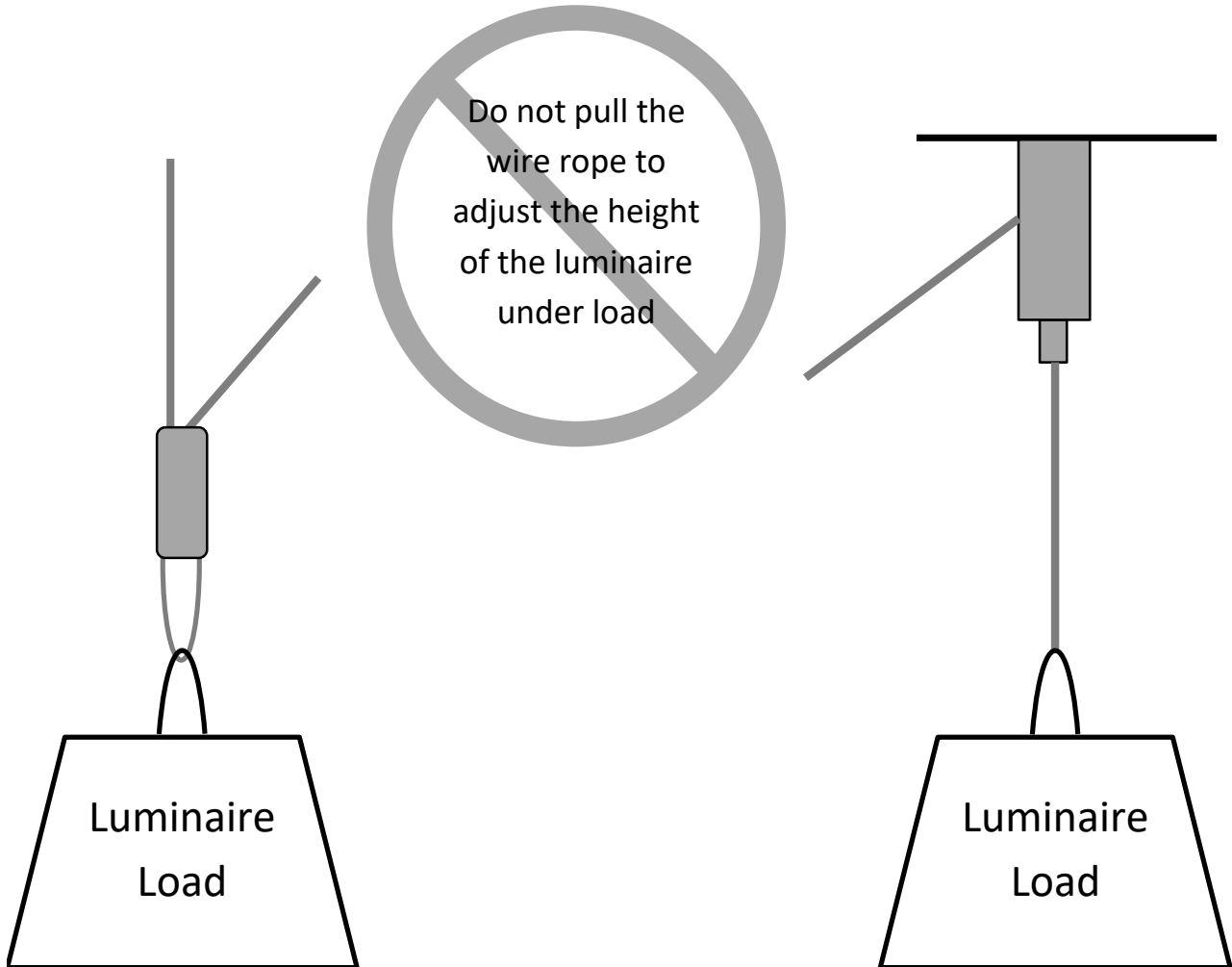

Warning Symbol Key

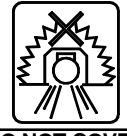

DO NOT COVER

Do not cover the luminaire with thermal insulation as may cause product to overheat and cause damage



HIGH VOLTAGE

High voltage warning against risk of electric shock



FALLING OBJECTS

Falling objects in areas where at risk from falling object hazards



GENERAL WARNING

General Warning used to denote areas of caution



HOT SURFACE

Hot surface to warn others around areas where there are any hot surfaces present



HIGH TEMPERATURE

High temperature displayed around areas where it is necessary to warn people about the dangers posed from any high temperature



EARTH

5019 Protective earth (ground) to identify any terminal which is intended for connection to an external conductor for protection against electrical shock in case of a fault, or the terminal of a protective earth (ground) electrode



ELECTROSTATIC DISCHARGE

ESD Electrostatic Discharge is intended to identify devices and assemblies that are susceptible to ESD